

# TECHNICAL PUBLICATION SUPPLEMENT

SUPPLEMENT No.	ENGINE MODEL	PUBLICATION No.	PUBLICATION DATE
PC-102-1-B	O-290-D Series	PC-102-1	January 1988

This supplement is arranged in the same basic format as the original parts catalog  
Insert in front of catalog for useage of subject matter.

Revised May, 1991

Page 4-1 — Magneto, Magneto Drive and Spark Plugs  
(Changes text of entire page)

# **TEXTRON** Lycoming

Williamsport Plant  
Textron Lycoming/Subsidiary of Textron Inc.

652 Oliver Street  
Williamsport, PA 17701 U.S.A.  
717/323-6181

## TECHNICAL PUBLICATION REVISION

REVISION No.	ENGINE MODEL	PUBLICATION No.	PUBLICATION DATE
PC-102-1-A	O-290-D Series	PC-102-1	January 1988
The page(s) furnished herewith are intended to replace the corresponding page(s) of the publication indicated above.			
Remove		Insert	
January 1988 Page 1-5, 1-6		September 1988 Page 1-5, 1-6	

TO: PARTS MANAGER

THIS PARTS CATALOG PC-102-1 DATED JANUARY, 1988 UPDATES AND REPLACES THE O-290 SERIES INFORMATION IN PC-102. THE O-235 SERIES INFORMATION HAS BEEN PREVIOUSLY UPDATED AND REPLACED BY PC-302 DATED JUNE, 1982.

YOU MAY NOW DESTROY COPIES OF PC-102 DATED AUGUST, 1973 AND REPLACE WITH THE PUBLICATIONS LISTED ABOVE.

# TEXTRON Lycoming AIRCRAFT ENGINES

## O-290-D SERIES

### PARTS CATALOG PC-102-1

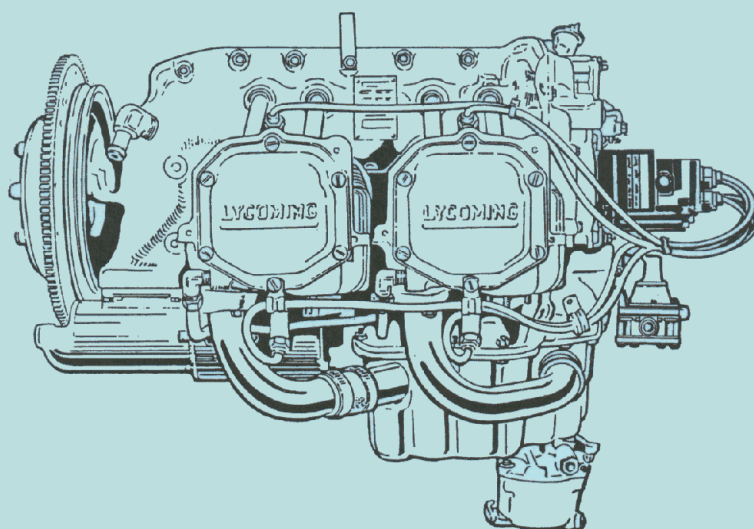

January 1988

---

**TEXTRON** Lycoming

Williamsport Plant  
Textron Lycoming/Subsidiary of Textron Inc.

652 Oliver Street  
Williamsport, PA 17701 U.S.A.  
717/323-6181

Williamsport Plant

## INTRODUCTION

This Parts Catalog supersedes PC-102 dated August, 1973.

This illustrated parts catalog contains a complete parts listing for the Textron Lycoming O-290-D series aircraft engines.

Major assembly and sub-assembly parts of the engines are listed in the Group Assembly sections in the general sequence of engine build up.

A Service Kits section and Oversize and Undersize Parts List are included to aid in ordering parts as necessary during overhaul.

The Numerical Index is provided for convenience in finding parts when only the part number is known.

Parts coverage of Vendor Accessories used on Textron Lycoming engines may be found in the appropriate Vendor's Parts Catalog. A list of these publications appear in the latest edition of Service Letter No. L114.

## NOTE

The illustrations, pictures and drawings shown in this publication are typical of the subject matter they portray.

*This catalog, when used in conjunction with the appropriate overhaul manual, shall be used for parts identification only. Under no circumstances shall this catalog be used as an assembly or installation document.*

Any reference in this document to a suppliers/parts manufacturers' product, by name, trademark, part number or other description is solely for the purposes of identification and does not indicate or infer that Textron Lycoming accepts responsibility for quality control and/or airworthiness of parts which do not pass through the Textron Lycoming quality control system.

## SERVICE BULLETINS, INSTRUCTIONS AND LETTERS

Although the information contained in this parts catalog is up-to-date at time of publication, users are advised to procure current information through all Textron Lycoming distributors or from the factory by subscription. Consult the latest edition of Service Letter No. L114 for subscription information.

## HOW TO ORDER PARTS

In ordering parts for your engine, observe the following instructions which will expedite shipment of correct parts required without delay.

- a. Always specify the model and serial number of your engine.
- b. Always specify Part Number, Nomenclature and quantity required.

Williamsport Plant

**TABLE OF CONTENTS**

<b>SECTION</b>	<b>PAGE</b>
Introduction .....	i
Table of Contents .....	ii
Oversize and Undersize Parts .....	iii
<b>1. CRANKCASE, CRANKSHAFT AND CAMSHAFT GROUP</b>	
Crankcase Assembly and Hydro Control .....	1-1
Oil Level Gage and Engine Mounting Hardware (Conical) .....	1-3
Crankcase Related Parts .....	1-5
Crankshaft, Camshaft and Related Parts .....	1-7
Crankshaft Idler Gears and Tachometer Shaft .....	1-9
Crankcase Attaching Parts .....	1-11
<b>2. ACCESSORY HOUSING AND RELATED PARTS</b>	
Accessory Housing Assembly .....	2-1
Oil Pump Assembly and Accessory Housing Attaching Parts .....	2-3
Fuel Pump Assembly .....	2-5
Oil Filter Assembly and Oil Cooler Bypass Valve .....	2-6
Vacuum Pump Drive and Cover .....	2-7
<b>3. CYLINDER, PISTON AND VALVE TRAIN</b>	
Connecting Rods, Pistons and Ring Assemblies .....	3-1
Cylinder Assembly .....	3-3
Valve Assembly .....	3-5
Cylinder Related Parts .....	3-7
<b>4. IGNITION SYSTEM</b>	
Magneto, Magneto Drive and Spark Plugs .....	4-1
<b>5. ELECTRICAL COMPONENTS</b>	
Alternator Assembly and Belt .....	5-1
Starter Motor and Attaching Parts .....	5-2
Alternator Mounting and Attaching Parts .....	5-3
<b>6. OIL SUMP AND INDUCTION SYSTEM</b>	
Oil Sump Assembly and Oil Suction Screen .....	6-1
Intake Pipe Assembly .....	6-3
Carburetor Assembly .....	6-5
Priming System .....	6-7
<b>7. SERVICE KIT SECTION</b> .....	7-1
<b>8. NUMERICAL INDEX</b> .....	8-1

Williamsport Plant

## Oversize and Undersize Parts Listing

PART NO.	DESCRIPTION	OVERSIZE								UNDERSIZE		
		P02 .002	P05 .005	P10 .010	P15 .015	P20 .020	P30 .030	P40 .040	P50 .050	M03 .003	M06 .006	M10 .010
61520	BEARING									X	X	X
61533	BEARING									X	X	X
61662	BEARING									X	X	X
62916	RING			X		X						
66528	SEAT						X					
66529-S	GUIDE	SEE LATEST EDITION OF SERVICE INSTRUCTION NO. 1256 FOR APPLICATION.										
66610	BUSHING		X	X								
66796	INSERT			X								
67447	BEARING									X	X	X
68338	RING			X		X						
68763	BEARING									X	X	X
69373	BEARING			X						X	X	X
69401	RING			X		X						
72057	SEAT			X		X	X					
72058	SEAT			X		X	X					
72067	BUSHING		X	X	X	X						
76943-S	GUIDE	SEE LATEST EDITION OF SERVICE INSTRUCTION NO. 1256 FOR APPLICATION.										
LW-11997	SEAL	SEE LATEST EDITION OF SERVICE INSTRUCTION NO. 1324 FOR APPLICATION.										
LW-13792	SEAL	SEE LATEST EDITION OF SERVICE INSTRUCTION NO. 1324 FOR APPLICATION.										
STD-1065	DOWEL	X	X	X	X							

Studs available in P03, P07 and P12 oversize.

## NOTE

When ordering oversize and undersize parts, be sure to specify the required oversize or undersize dimension along with the proper part number. For example: to order bearing 67447 in .003 undersize, order part number 67447-M3. Oversize code is 'P' while undersize code letter is 'M'. These letters are then followed by the numbers designating the size in thousandths of an inch.

Williamsport Plant

**CRANKCASE, CRANKSHAFT AND CAMSHAFT GROUP**  
 CRANKCASE ASSEMBLY AND HYDRO CONTROL

FIG. REF. 1	PART NUMBER	DESCRIPTION	O N A L L	QUANTITY PER ASSEMBLY			
				D	D2	D2B	D2C
1	LW-10070*	CRANKCASE ASSEMBLY			1	1	1
	LW-10071*	CRANKCASE ASSEMBLY		1			
2	STD-557	DOWEL, 1/2 dia. x 11/16 long, hollow	2				
3	66734	STUD, 1/2-13 x 9-7/8 long	4				
4	50-15	STUD, 1/2-13 x 1-7/8 long	8				
5	38-13	STUD, 3/8-16 x 1-5/8 long	16				
6	69679	STUD, 9/16-18 x 10-21/32 long		2			
	68751	STUD, 1/2-20 x 10-21/32 long			2	2	2
7	31C-12	STUD, 5/16-18 x 1-1/2 long	2				
8	31C-13	STUD, 5/16-18 x 1-5/8 long	1				
9	1102	PLUG, 1/8-27 NPT, Allen		4			
	1102	PLUG, 1/8-27 NPT, Allen			6	6	6
10	65007	RETAINER, Shroud tube seal			8	8	8
11	STD-514	DOWEL, 5/16 dia. x 1/2 long	2				
12	STD-1111	ELBOW, 3/4 pipe & hose, 90°	1				
13	STD-1623	INSERT, 1/4-20 Helicoil x 3/8 long, notched	2				
14	61555**	PLUG, Hydraulic valve hole	1				
15	61531	GASKET, Hydraulic valve	1				
16	61584	VALVE, Hydraulic			1	1	
17	61583	COVER ASSY., Hydraulic valve			1	1	
18	LW-14260	SEAL, Oil			1	1	
19	61227	LEVER, Hydraulic valve			1	1	
20	STD-131	SCREW, 1/4-28 x 1.00 hex. hd.			1	1	
21	STD-43	NUT, 1/4-28 slotted shear			1	1	
22	STD-68	PIN, 1/16 x 1/2 long, cotter			1	1	
23	61554* (**)	COVER, Hydraulic valve hole plug	1				
24	STD-160	WASHER, 1/4 lock, internal teeth	2				
25	STD-8	WASHER, 1/4 plain	2				
26	LW-25-0.94	BOLT, 1/4-20 x 15/16 long, hex. hd.	2				

\* These parts are no longer available for purchase through Textron Lycoming.

\*\* When P/N 61584 valve is removed, P/N 61555 plug and P/N 61554 cover are installed.

Williamsport Plant

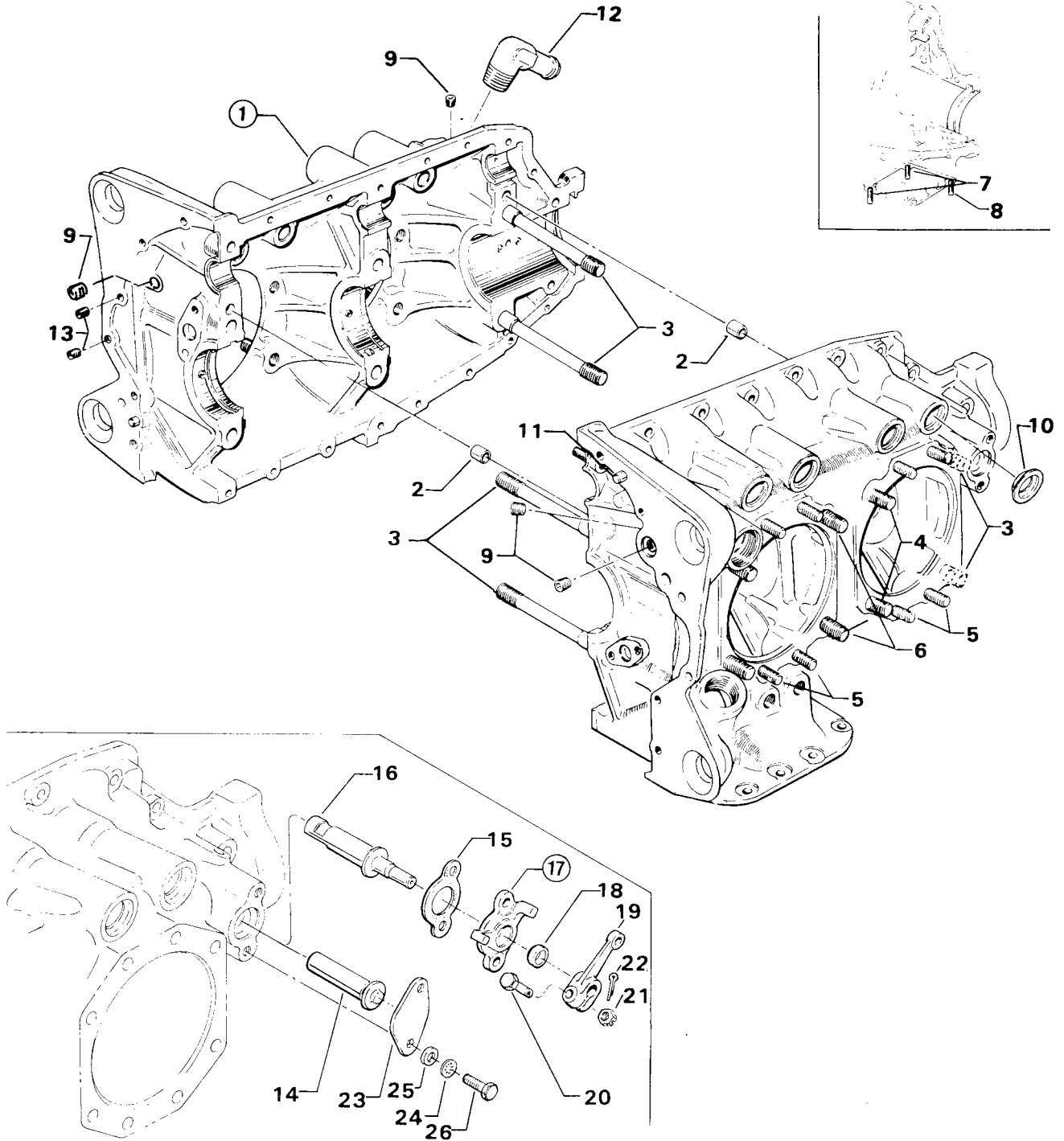

3161

Figure 1. CRANKCASE ASSEMBLY

Williamsport Plant

**CRANKCASE, CRANKSHAFT AND CAMSHAFT GROUP**  
OIL LEVEL GAGE AND ENGINE MOUNTING HARDWARE (CONICAL)

FIG. REF. 2	PART NUMBER	DESCRIPTION	O N A L L	QUANTITY PER ASSEMBLY			
				D	D2	D2B	D2C
1	74068	RING, Oil level gage seal	1				
2	LW-14759	GAGE ASSY., Oil level	1				
3	62123	TUBE ASSY., Oil level gage	1				
4	71032	BUSHING, Engine support	8				
5	STD-619	WASHER, 17/32 I.D. x 1-3/4 O.D. x 5/32 thick	8				

Williamsport Plant

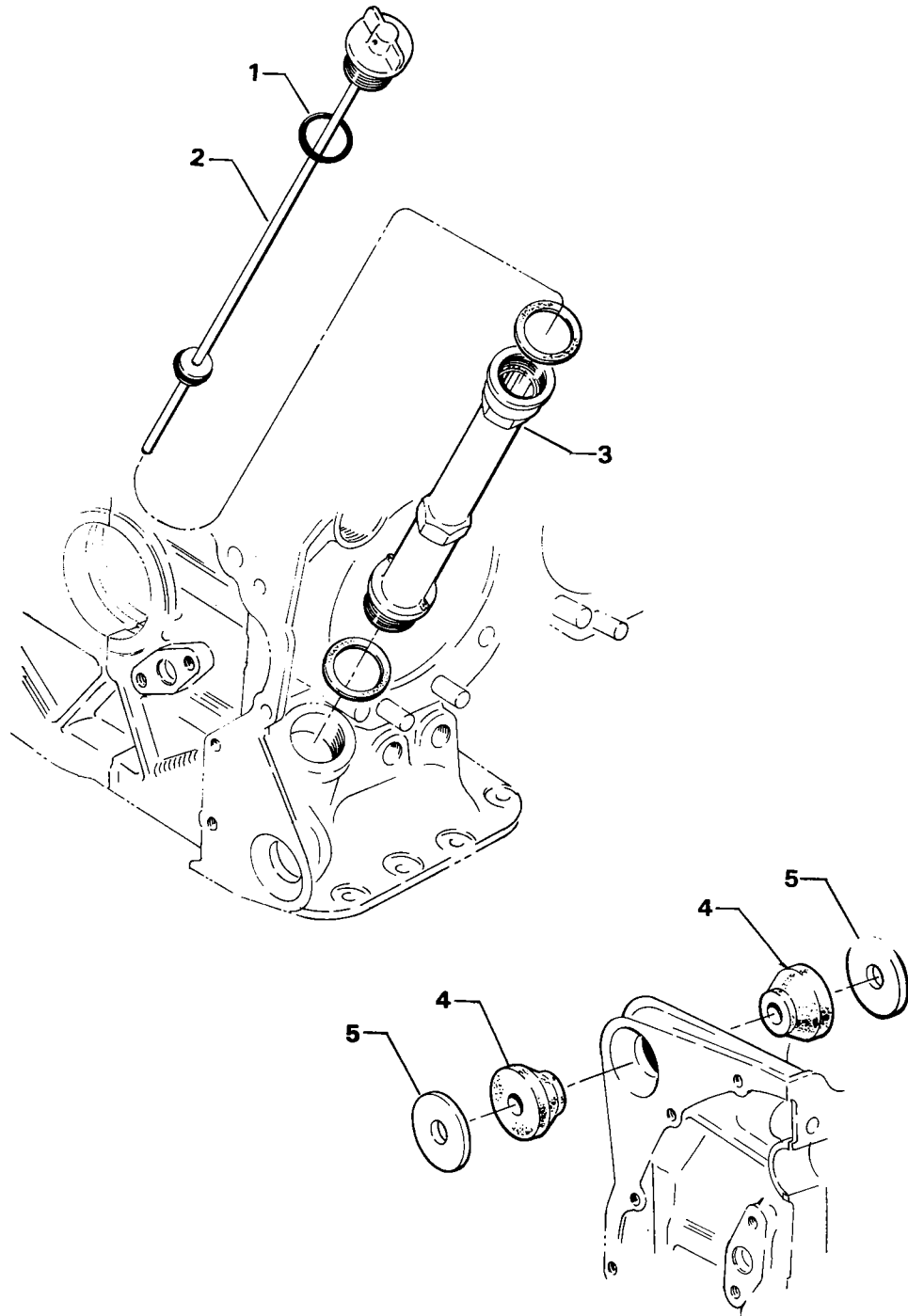

3162

**Figure 2. OIL LEVEL GAGE AND ENGINE MOUNTING HARDWARE (CONICAL)**

Williamsport Plant

## CRANKCASE, CRANKSHAFT AND CAMSHAFT GROUP CRANKCASE RELATED PARTS

FIG. REF. 3	PART NUMBER	DESCRIPTION	O N A L L	QUANTITY PER ASSEMBLY			
				D	D2	D2B	D2C
1	1028-B	BALL, 11/16 diameter	1				
2	61084 *	SPRING, Oil pressure relief valve	1				
	68668 *	SPRING, Oil pressure relief valve	1				
	77467 *	SPRING, Oil pressure relief valve	1				
	LW-11713 *	SPRING, Oil pressure relief valve	1				
3	STD-425	WASHER, No. 10 plain (max. 9)	AR				
4	STD-1045	GASKET, 1-1/4 I.D. x 1-1/2 O.D. x 3/32 annular	1				
5	76529	PLUG, Oil relief valve	1				
6	67447	BEARING, Crankshaft	8				
	68763	BEARING, Crankshaft (alternate)	8				
7	61533 *	BEARING, Crankshaft, right front	1				
8	61520 *	BEARING, Crankshaft, left front	1				
9	LW-13792 **	SEAL, Crankshaft oil, solid	1				
	LW-11997 **	SEAL, Crankshaft oil, split	1				
10	72075	SEAL, Oil, 3/32 section x 15/32 I.D.	6				
11	72091	RING, Oil seal, 23/64 I.D. x 7/64 dia.	2				
12	71105	TAPPET, Valve		8			
	72877	BODY, Hydraulic tappet			8	8	8

\* Select spring to give a minimum of three threads exposed on adjusting screw to allow field adjustment. Reference latest revision of SSP-1776, Part 1 for spring identification.

\*\* Refer to the latest edition of Textron Lycoming Service Instruction No. 1324 for installation.

\* Replace two P/N 67447, or P/N 68763 (alternate), crankshaft bearings with one P/N 61533 (right) and one P/N 61520 (left) bearing at front main when hydro control propeller is used.

Williamsport Plant

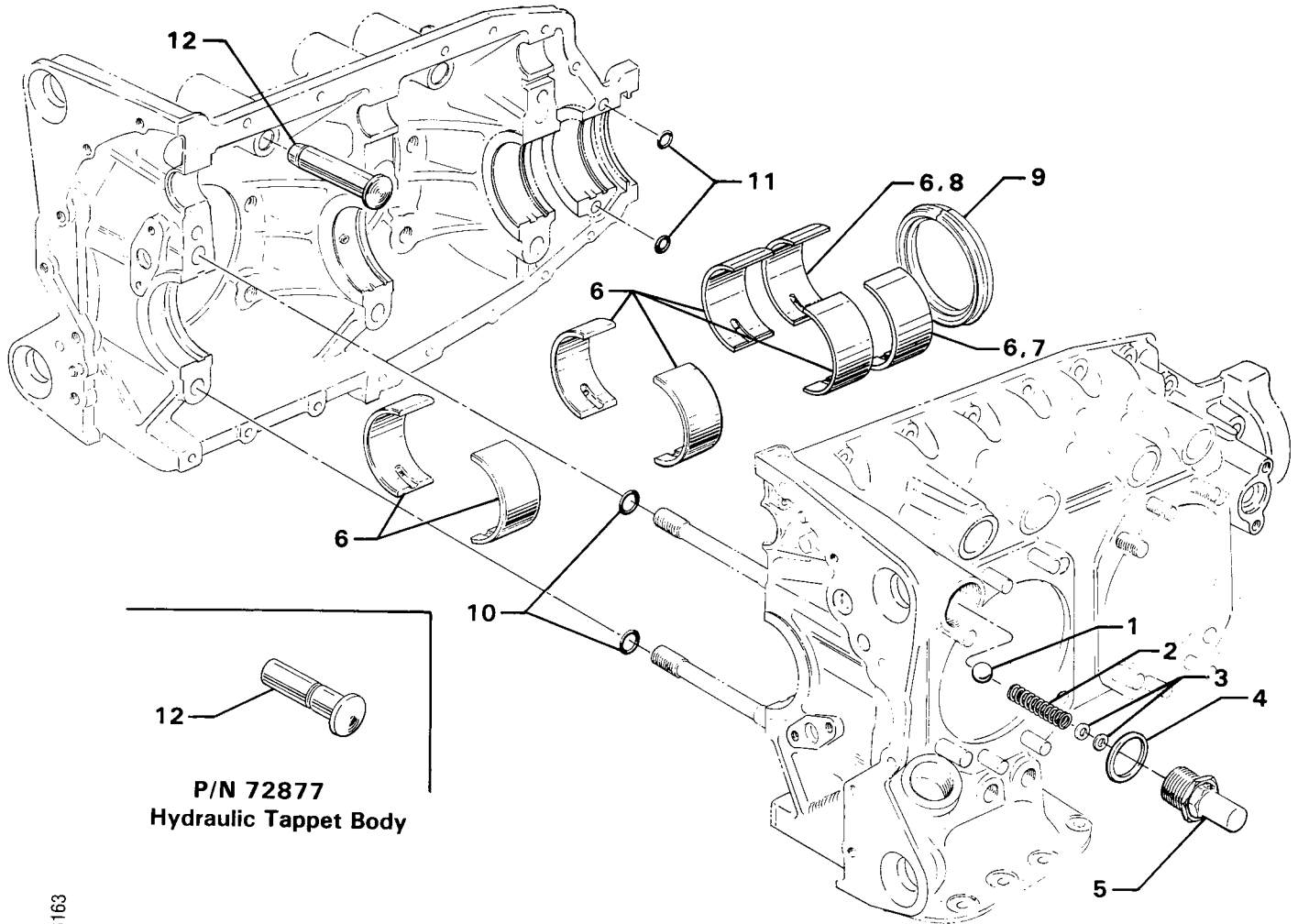

3163

**Figure 3. CRANKCASE RELATED PARTS**

Williamsport Plant

**CRANKCASE, CRANKSHAFT AND CAMSHAFT GROUP**  
 CRANKSHAFT, CAMSHAFT AND RELATED PARTS

FIG. REF. 4	PART NUMBER	DESCRIPTION	O N A L L	QUANTITY PER ASSEMBLY			
				D	D2	D2B	D2C
1	62531*	CRANKSHAFT ASSEMBLY	1				
2	STD-1211	PLUG, 2.00 dia. expansion	1				
3	STD-1065	DOWEL, Stepped, 19/64-1/4 dia. x 35/64 long	1				
4	72067	BUSHING, Propeller flange	6				
5	61510	PLUG, 1-3/4 O.D.	1				
6	13S19646‡	GEAR, Crankshaft	1				
7	LW-18639	LOCKPLATE, Crankshaft gear	1				
8	STD-2213	SCREW, 5/16-24 x 1.00 long	1				
9	69340**	SUPPORT ASSY., Starter ring gear, 10/12 pitch		1	1	1	1
	75312★	SUPPORT ASSY., Starter ring gear, 12/14 pitch		1	1	1	
10	60882**	GEAR, Starter ring, 10/12 pitch		1	1	1	1
	72566★	GEAR, Starter ring, 12/14 pitch		1	1	1	
11	61253* (●)	SPACER, Propeller hub		1	1		
12	STD-1214	SCREW, No. 10-32 x 3/8 long	2				
13	45688	FLANGE, Propeller	1				
14	STD-33	WASHER, 3/8 plain	6				
15	STD-1198	BOLT, 3/8-24 x 4-7/16 long, hex. hd., dr. hd.	6				
16	75706	CAMSHAFT		1			
	76094	CAMSHAFT			1	1	1

\* These parts are no longer available for purchase through Textron Lycoming.

\*\* Used with P/N 76210 or P/N 69953 starter.

★ Used with P/N LW-15571 starter.

● Required when no starter ring gear support assembly is used.

‡ See latest edition of Textron Lycoming Service Bulletin No. 475 for correct installation.

Williamsport Plant

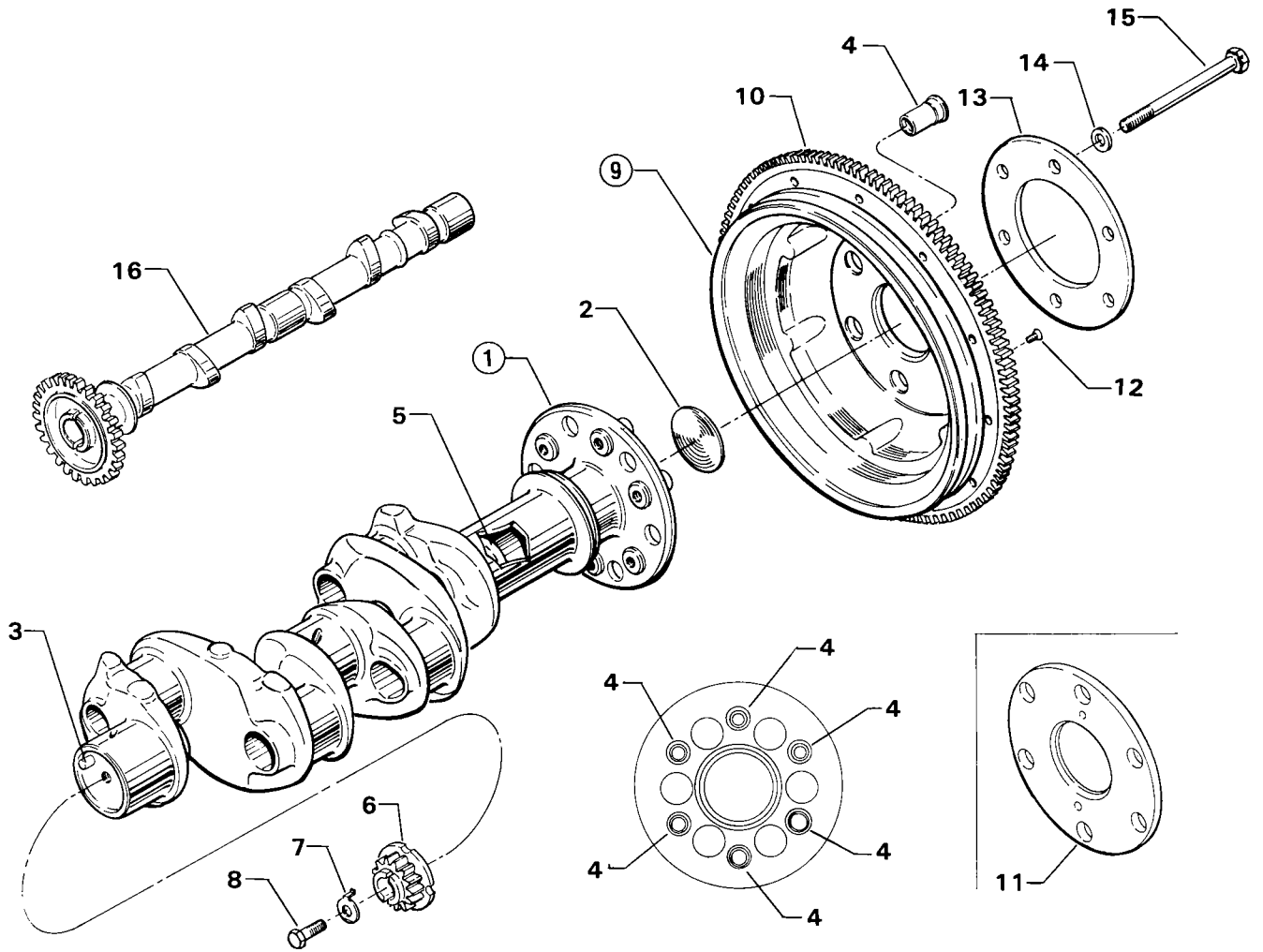

Figure 4. CRANKSHAFT, CAMSHAFT AND RELATED PARTS

Williamsport Plant

**CRANKCASE, CRANKSHAFT AND CAMSHAFT GROUP**  
**CRANKSHAFT IDLER GEARS AND TACHOMETER SHAFT**

FIG. REF. 5	PART NUMBER	DESCRIPTION	O N A L L	QUANTITY PER ASSEMBLY			
				D	D2	D2B	D2C
1	61544*	PLUNGER, Fuel pump, long		1	1	1	1
2	74996*	GEAR ASSY., Crankshaft idler, plain		1	1	1	1
	74996**	GEAR ASSY., Crankshaft idler, plain		2	2	2	2
3	77309*	BUSHING, Crankshaft idler gear		1	1	1	1
	77309**	BUSHING, Crankshaft idler gear		2	2	2	2
4	75072*	GEAR ASSY., Crankshaft idler		1	1	1	1
5	77309*	BUSHING, Crankshaft idler gear		1	1	1	1
6	75708	SHAFT ASSY., Tachometer	1				
7	LW-18667	PIN, 3/16 dia. x 2-21/64 long	1				
8	45530	RING, Oil pump shaft retaining	1				
9	61151	SHAFT, Crankshaft idler gear	2				
10	73817	LOCKPLATE, 5/16 bolt, 1-3/4 spacing	2				
11	LW-25-0.63	BOLT, 1/4-20 NC-3 x 5/8 long, hex. hd.	4				

\* Diaphragm fuel pump drive.  
 \*\* AN fuel pump drive.

Williamsport Plant

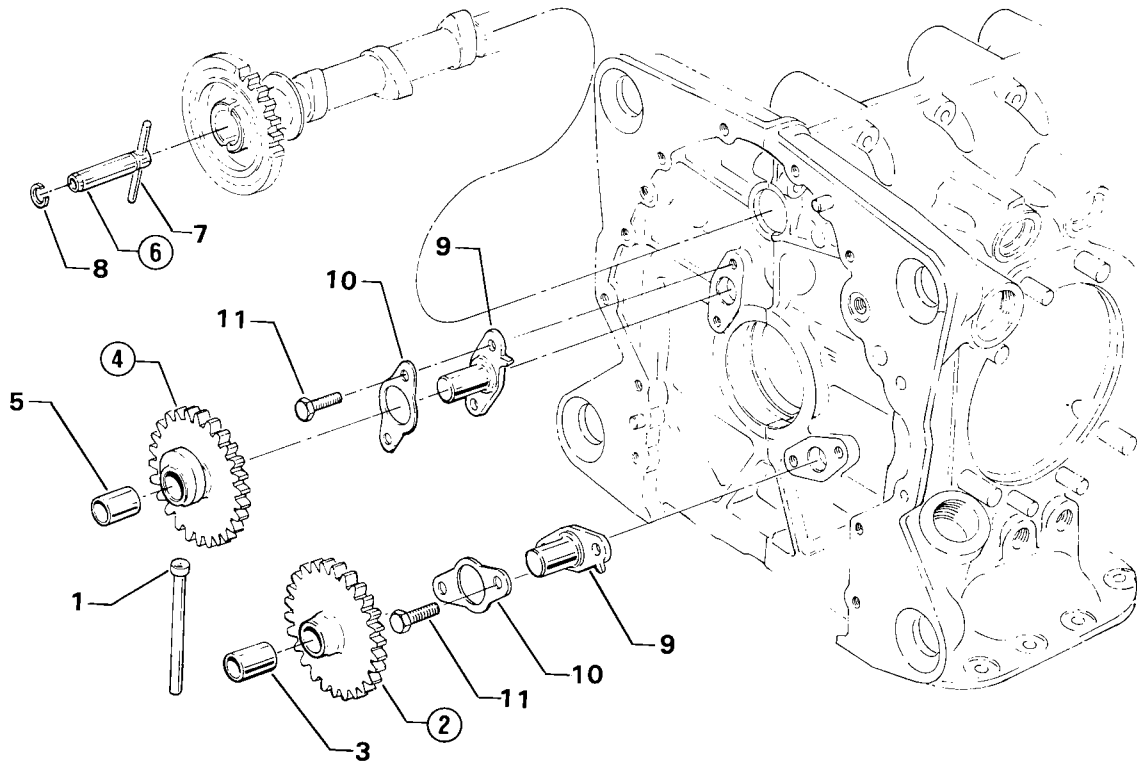

Figure 5. CRANKSHAFT IDLER GEARS AND TACHOMETER SHAFT

Williamsport Plant

**CRANKCASE, CRANKSHAFT AND CAMSHAFT GROUP  
CRANKCASE ATTACHING PARTS**

FIG. REF. 6	PART NUMBER	DESCRIPTION	O N A L L	QUANTITY PER ASSEMBLY			
				D	D2	D2B	D2C
1	LW-25-1.50	BOLT, 1/4-20 x 1-1/2 long, hex. hd.	8				
2	STD-8	WASHER, 1/4 plain	16				
3	60803	STRAP, Lifting	1				
4	LW-25-1.75	BOLT, 1/4-20 x 1-3/4 long, hex. hd.	1				
5	STD-160	WASHER, 1/4 lock, internal teeth	9				
6	STD-1411	NUT, 1/4-20 plain	9				
7	LW-25S1.50	BOLT, 1/4-20 x 1-1/2 long, hex. hd., dr. end	3				
8	STD-8	WASHER, 1/4 plain (max. 9)	AR				
9	STD-1409	NUT, 1/4-20 slotted shear	3				
10	AN6-21	BOLT, 3/8-24 x 2-13/64 long, hex. hd.	1				
11	STD-33	WASHER, 3/8 plain	2				
12	STD-872	NUT, 3/8-24 slotted	1				
13	AN6-34A	BOLT, 3/8-24 x 3-37/64 long, hex. hd.	2				
14	STD-33	WASHER, 3/8 plain	4				
15	STD-678	WASHER, 3/8 lock, internal teeth	2				
16	STD-596	NUT, 3/8-24 plain	2				
17	LW-25-1.50	BOLT, 1/4-20 x 1-1/2 long, hex. hd.		1	1	1	
18	LW-25-1.13	BOLT, 1/4-20 x 1-1/8 long, hex. hd.		2	2	2	
19	STD-8	WASHER, 1/4 plain		4	4	4	
20	STD-160	WASHER, 1/4 lock, internal teeth		3	3	3	
21	STD-1411	NUT, 1/4-20 plain		1	1	1	

Williamsport Plant

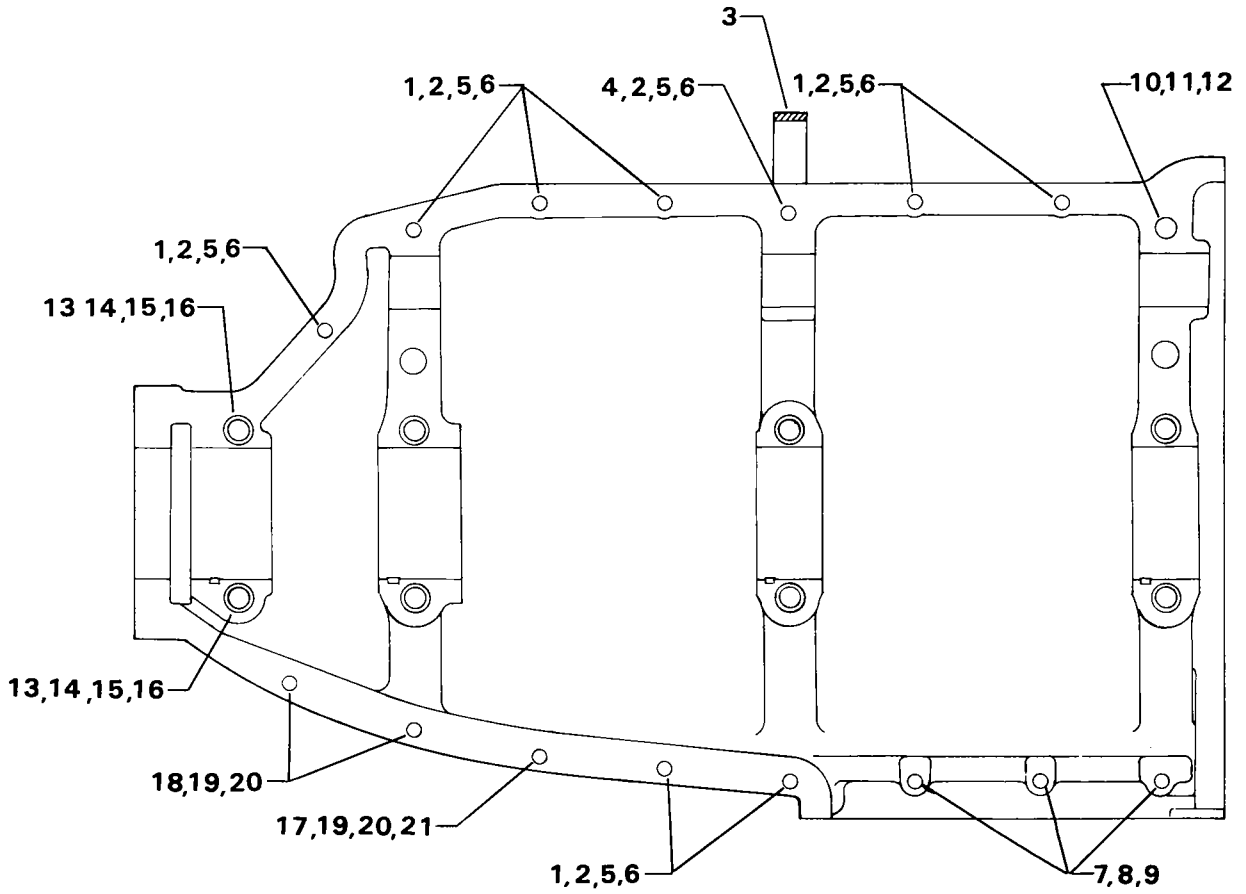

Figure 6. CRANKCASE ATTACHING PARTS

Williamsport Plant

**ACCESSORY HOUSING AND RELATED PARTS**  
ACCESSORY HOUSING ASSEMBLY

FIG. REF. 7	PART NUMBER	DESCRIPTION	O N A L L	QUANTITY PER ASSEMBLY			
				D	D2	D2B	D2C
1	73818	GASKET, Accessory housing	1				
2	68786★	HOUSING ASSY., Accessory		1	1	1	
	68788★★	HOUSING ASSY., Accessory		1	1	1	
	68790★	HOUSING ASSY., Accessory		1	1	1	
	68792●	HOUSING ASSY., Accessory		1	1	1	
	71160‡	HOUSING ASSY., Accessory				1	
	72496	HOUSING ASSY., Accessory					1
3	31C-12	STUD, 5/16-18 x 1-1/2 long					2
	31C-12★	STUD, 5/16-18 x 1-1/2 long		2	2	2	
	31C-12★★	STUD, 5/16-18 x 1-1/2 long		2	2	2	
	31C-12★	STUD, 5/16-18 x 1-1/2 long		2	2	2	
	31C-12●	STUD, 5/16-18 x 1-1/2 long		2	2	2	
4	31C-19★	STUD, 5/16-18 x 2-3/8 long		2	2	2	
	31C-19★★	STUD, 5/16-18 x 2-3/8 long		2	2	2	
	31C-19★	STUD, 5/16-18 x 2-3/8 long		2	2	2	
	31C-19●	STUD, 5/16-18 x 2-3/8 long		2	2	2	
	31C-19‡	STUD, 5/16-18 x 2-3/8 long				4	
5	25C-22	STUD, 1/4-20 x 2-3/4 long					4
	25C-22★	STUD, 1/4-20 x 2-3/4 long		4	4	4	
	25C-22●	STUD, 1/4-20 x 2-3/4 long		4	4	4	
	25C-22‡	STUD, 1/4-20 x 2-3/4 long				4	
6	31CD-17	STUD, 5/16-18 x 2-1/8 long, drilled	3				
7	STD-784	PLUG, 3/8-18 NPT, Allen					1
	STD-784★	PLUG, 3/8-18 NPT, Allen		1	1	1	
	STD-784●	PLUG, 3/8-18 NPT, Allen		1	1	1	
	STD-784‡	PLUG, 3/8-18 NPT, Allen				1	
8	1102	PLUG, 1/8-27 NPT, Allen	2				
9	61175	ADAPTER, Tachometer	1				
10	STD-783	PLUG, 1/4-18 NPT, Allen	1				
11	61400	STUD, 1/4-20 x 1-3/16 long	2				

- ★ This accessory housing assembly has the oil cooler line adapter cast as an integral part of the housing but is not machined for fuel, hydraulic or vacuum pump drives.
- ★★ This accessory housing assembly has the oil cooler line adapter cast as an integral part of the housing and is machined for a diaphragm type fuel pump only.
- ★ This accessory housing assembly has the oil cooler line adapter cast as an integral part of the housing and is machined for a vacuum pump drive only.
- This accessory housing assembly has the oil cooler line adapter cast as an integral part of the housing and is machined for a diaphragm type fuel pump and vacuum pump drive.
- ‡ This accessory housing assembly is machined for vacuum and fuel pump drives and is studded to receive two (2) 35° lag impulse magnetos.

Williamsport Plant

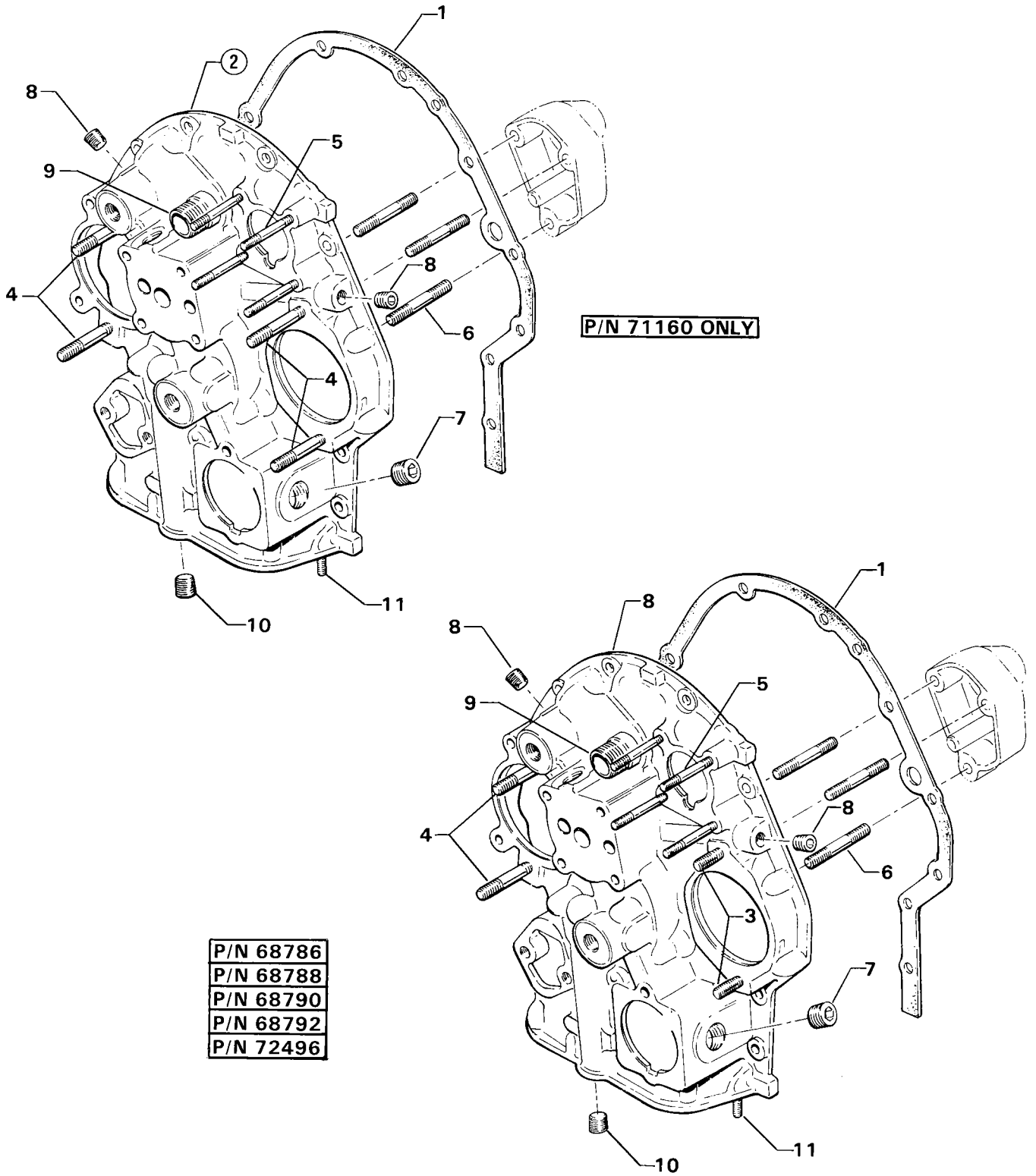

3165

Figure 7. ACCESSORY HOUSING ASSEMBLY

Williamsport Plant

**ACCESSORY HOUSING AND RELATED PARTS**  
**OIL PUMP ASSEMBLY AND ACCESSORY HOUSING ATTACHING PARTS**

FIG. REF. 8	PART NUMBER	DESCRIPTION	O N A L L	QUANTITY PER ASSEMBLY			
				D	D2	D2B	D2C
1	78531	BODY, Oil pump	1				
2	05K19423-S *	OIL PUMP IMPELLER KIT	1				
3	61174	SHAFT, Oil pump drive	1				
4	STD-35	WASHER, 5/16 plain	3				
5	STD-1420	NUT, 5/16-18 slotted	3				
6	LW-14260	SEAL, Tachometer drive, oil	1				
7	STD-8	WASHER, 1/4 plain	12				
8	STD-160	WASHER, 1/4 lock, internal teeth	12				
9	LW-25-0.94	BOLT, 1/4-20 x 15/16 long, hex. hd.	10				
10	LW-25-1.50	BOLT, 1/4-20 x 1-1/2 long, hex. hd.	2				

\* To insure that new impellers are used together, they must be purchased in this kit.

Williamsport Plant

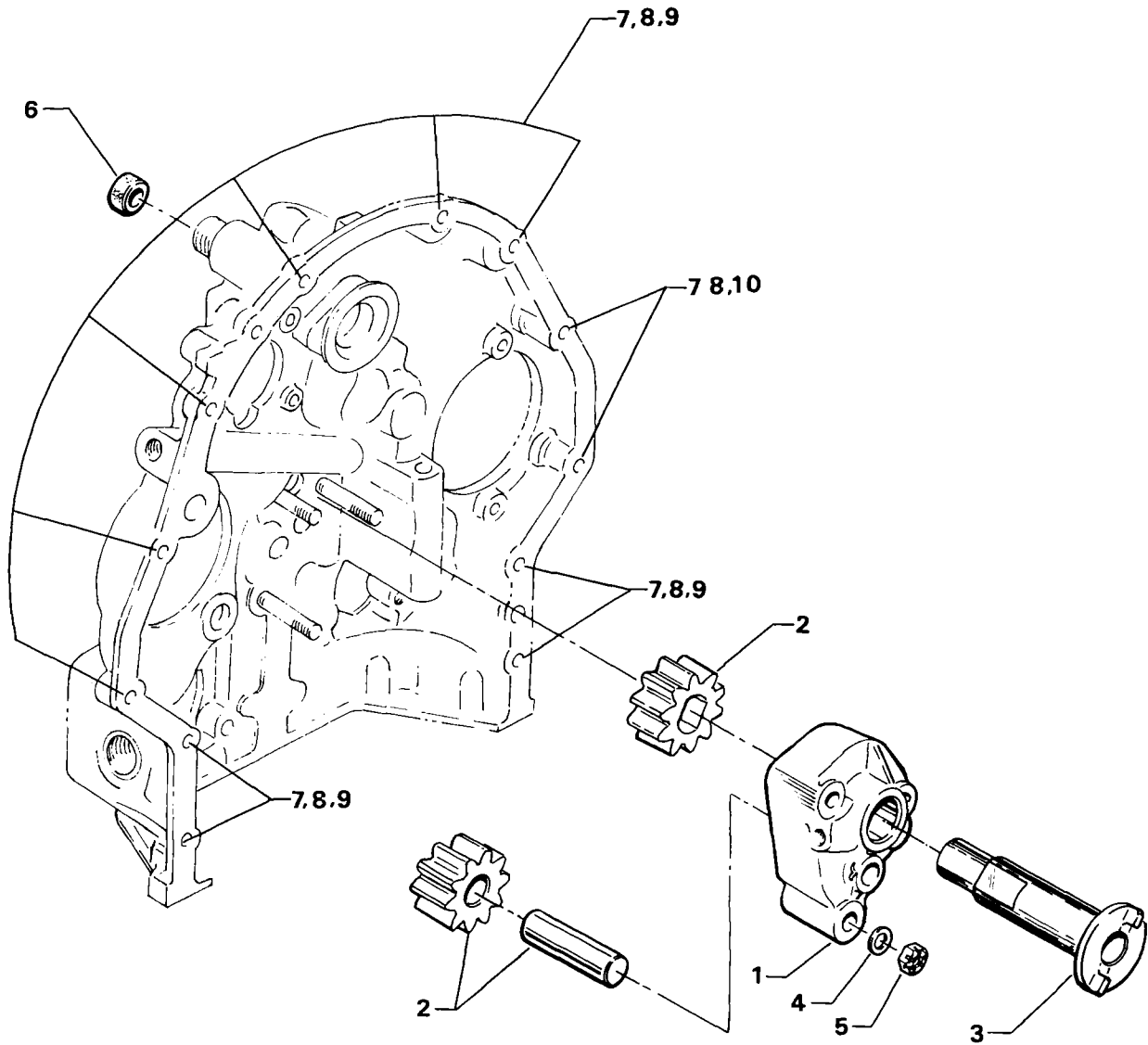
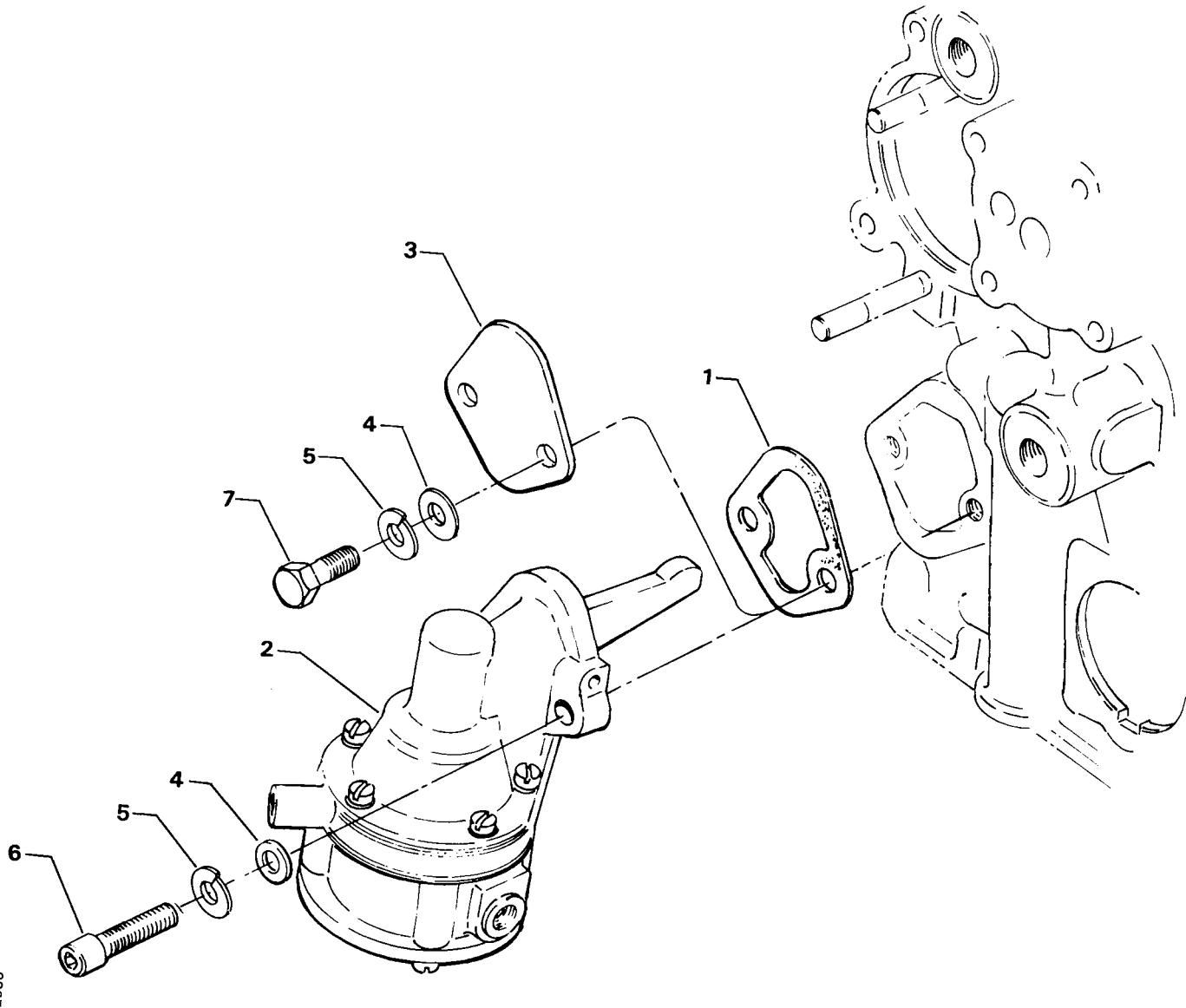

**Figure 8. OIL PUMP ASSEMBLY AND ACCESSORY HOUSING ATTACHING PARTS**

Williamsport Plant

**ACCESSORY HOUSING AND RELATED PARTS  
FUEL PUMP ASSEMBLY**

FIG. REF. 9	PART NUMBER	DESCRIPTION	O N A L L	QUANTITY PER ASSEMBLY			
				D	D2	D2B	D2C
1	60096	GASKET, Fuel pump	1				
2	LW-15472	FUEL PUMP, (6441271) Low pressure, dual diaphragm		1	1	1	
3	65098	COVER, Fuel pump		1	1		1
4	STD-33	WASHER, 3/8 plain	2				
5	STD-678	WASHER, Lock		2	2		2
6	STD-1882	SCREW, 3/8-16 x 1-9/32 long, socket hd., dr. hd.		2	2	2	
7	LW-38-0.75	BOLT, 3/8-16 x 3/4 long, hex. hd.		2	2		2



**Figure 9. FUEL PUMP ASSEMBLY**

Williamsport Plant

**ACCESSORY HOUSING AND RELATED PARTS  
OIL FILTER ASSEMBLY AND OIL COOLER BYPASS VALVE**

FIG. REF. 10	PART NUMBER	DESCRIPTION	O N A L L	QUANTITY PER ASSEMBLY			
				D	D2	D2B	D2C
1	69436	SPRING, Oil cooler bypass	1				
2	62415	PLUNGER, Oil cooler bypass	1				
3	STD-294	GASKET, 7/8 O.D. x 5/8 I.D. x 3/32 annular	1				
4	62417	PLUG, Oil cooler bypass	1				
5	62817	SCREEN ASSY., Oil pressure	1				
6	61173	GASKET, Oil pressure housing	1				
7	62815*	HOUSING, Oil pressure screen		1	1		
	68974	HOUSING, Oil pressure screen		1	1	1	1
8	STD-294	GASKET, 7/8 O.D. x 5/8 I.D. x 3/32 annular	1				
9	STD-8	WASHER, 1/4 plain	4				
10	STD-1856	SCREW, 1/4-20 x 1.00 long, hex. hd., slotted	4				

\* For use with 5/8-18 threaded thermostatic connection.

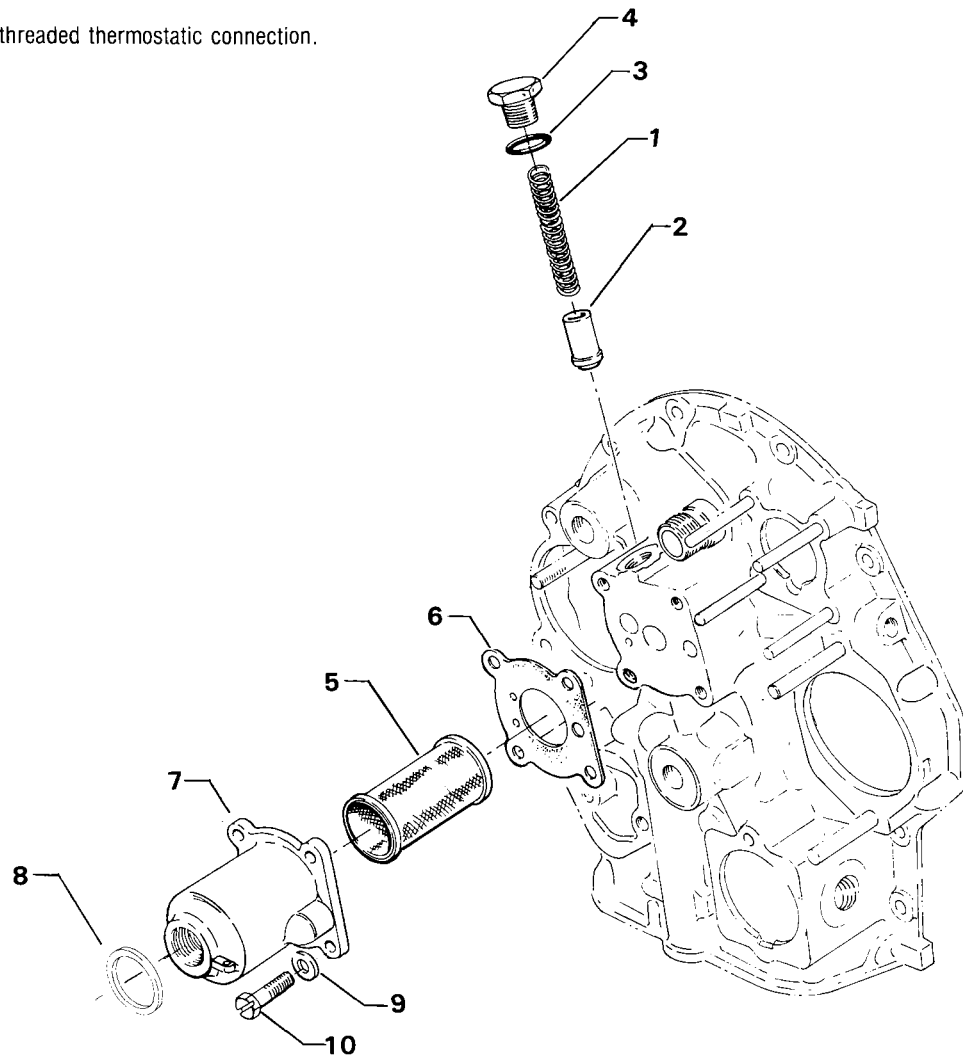

**Figure 10. OIL FILTER ASSEMBLY AND OIL COOLER BYPASS VALVE**

3167

Williamsport Plant

**ACCESSORY HOUSING AND RELATED PARTS  
VACUUM PUMP DRIVE AND COVER**

FIG. REF. 11	PART NUMBER	DESCRIPTION	O N A L L	QUANTITY PER ASSEMBLY			
				D	D2	D2B	D2C
1	61183	GASKET, Accessory adapter	1				
2	61098	ADAPTER ASSY., Vacuum pump	1				
3	STD-1774	PIN, 1/8 dia. x 1/4 long	1				
4	STD-2217	OIL SEAL, 7/8 I.D. x 1-1/2 O.D. x 5/16 wide	1				
5	72970	GEAR ASSY., Vacuum pump driven	1				
6	71596	WASHER, Accessory driven gear	1				
7	8313	GASKET, Vacuum pump	1				
8	60430	COVER, Vacuum pump	1				
9	68593	SPACER, Vacuum pump stud			4	4	
10	STD-8	WASHER, 1/4 plain	4				
11	STD-160	WASHER, 1/4 lock, internal teeth	4				
12	STD-1411	NUT, 1/4-20 plain	4				

Williamsport Plant

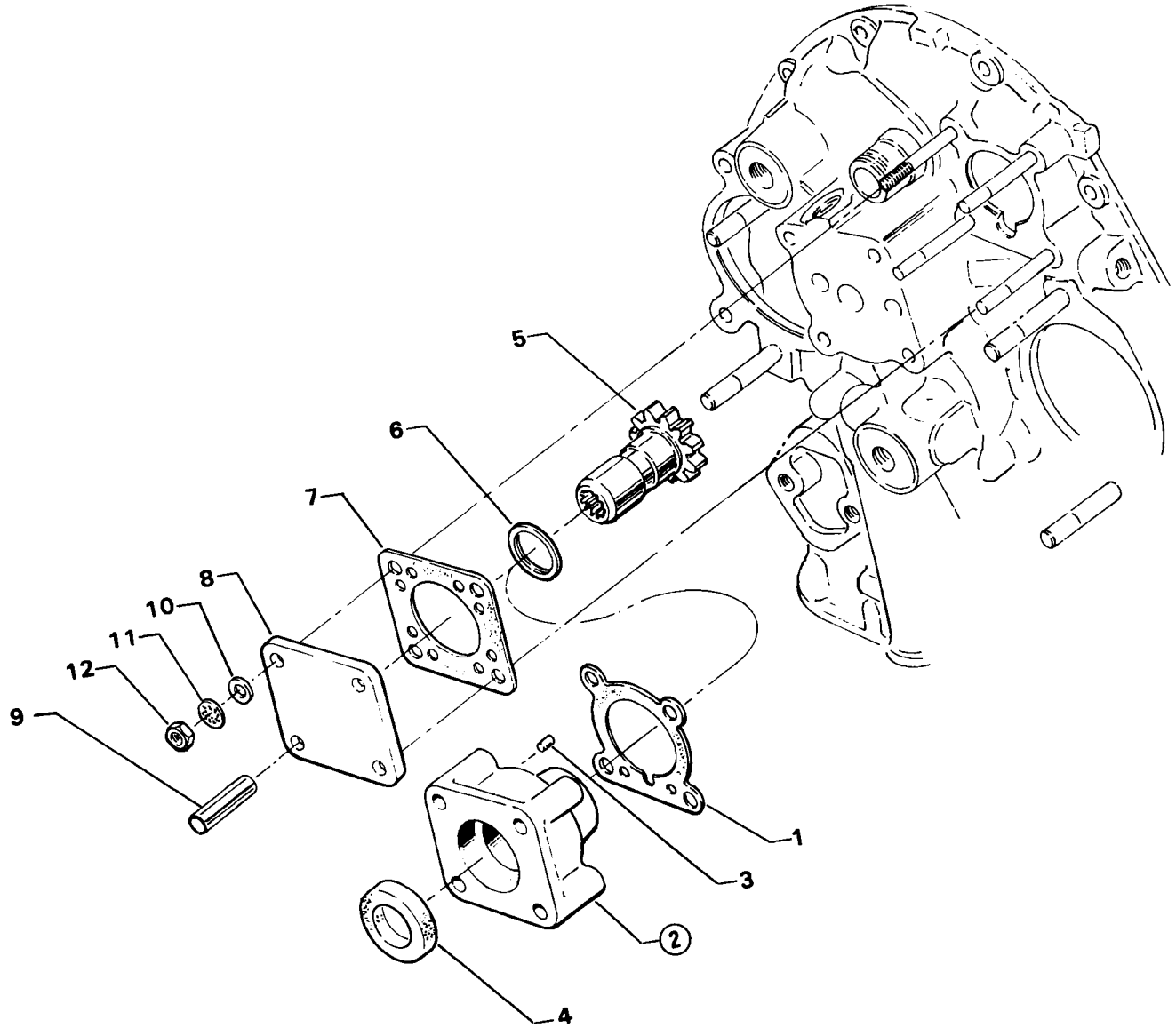

2591

**Figure 11. VACUUM PUMP DRIVE AND COVER**

Williamsport Plant

**CYLINDER, PISTON AND VALVE TRAIN  
CONNECTING RODS, PISTONS AND RING ASSEMBLIES**

FIG. REF. 12	PART NUMBER	DESCRIPTION	O N A L L	QUANTITY PER ASSEMBLY			
				D	D2	D2B	D2C
1	78030-S	CONNECTING ROD ASSEMBLY	4				
2	LW-13923	BUSHING, Connecting rod, upper	4				
3	78027	BOLT, Connecting rod	8				
4	LW-12186	NUT, Connecting rod	8				
5	61662	BEARING, Connecting rod	8				
	69373	BEARING, Connecting rod (alternate)	8				
6	69958	PISTON, Compression ratio 6.5:1		4			
	69841	PISTON, Compression ratio 7.5:1			4		
	70396	PISTON, Compression ratio 7.0:1				4	4
7	60403	PIN, Piston		4	4	4	4
8	60311★	PLUG, Piston		8	8	8	8
	72434★★	PLUG, Piston		8	8	8	
9	62916★	RING, Piston top compression		8	8	8	8
	LW-13883●	RING, Piston, top and 2nd compression		8	8	8	
10	69401★	RING, Piston, oil regulating		4	4		
	68338●	RING, Piston, oil regulating		4	4	4	4

- \* Used in unplated barrels only.
- \*\* Used in chrome barrels only.
- ★ Chrome.
- Plain.

**NOTE**

Do not under any circumstances assemble chrome plated piston rings in a chrome plated cylinder barrel. Chrome plated cylinders are identified by an orange band around the base of the cylinder barrel or orange paint on the cylinder fins between the push rods.

Williamsport Plant

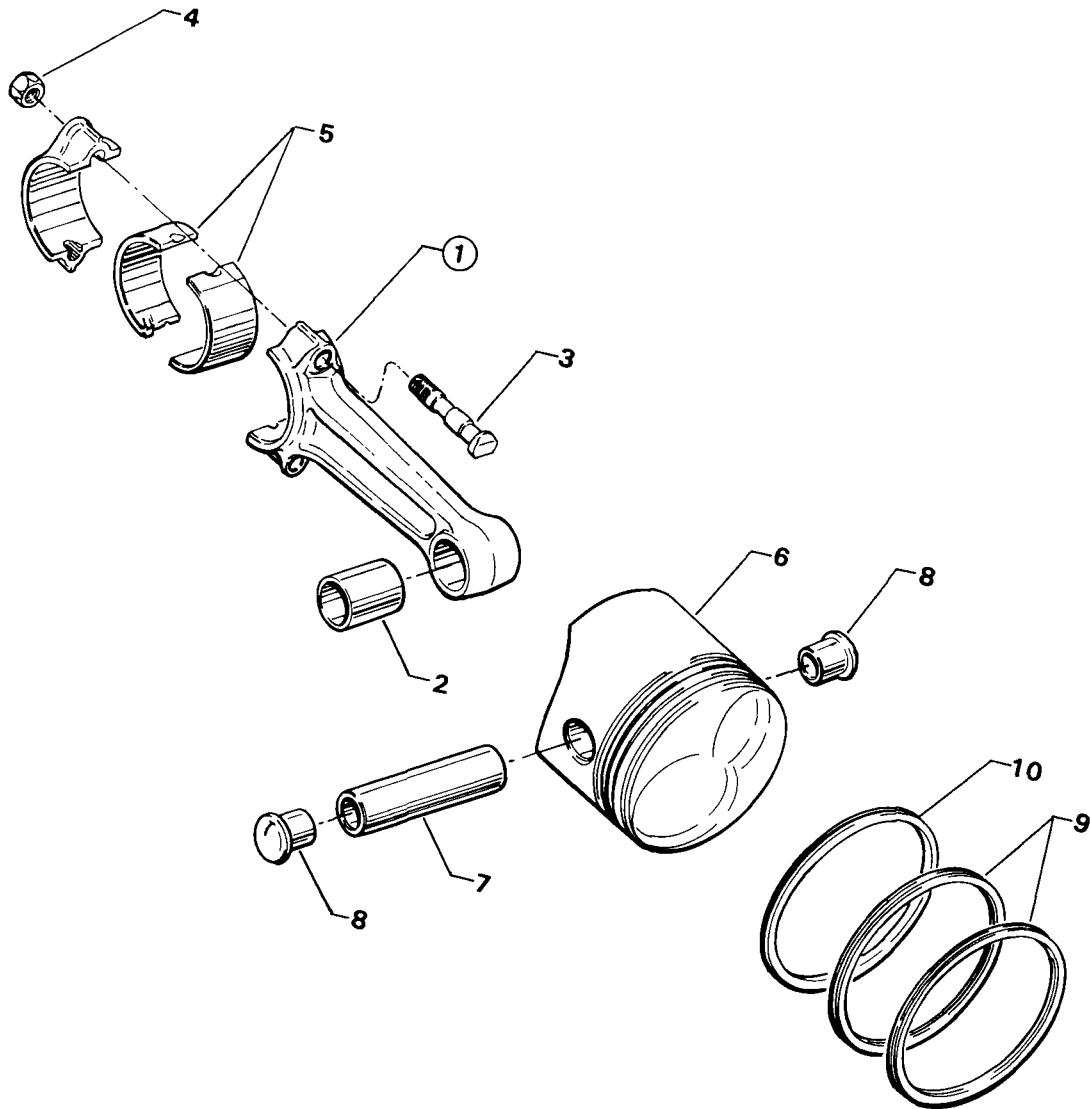

2580

Figure 12. CONNECTING RODS, PISTONS AND RING ASSEMBLIES

Williamsport Plant

**CYLINDER, PISTON AND VALVE TRAIN  
CYLINDER ASSEMBLY**

FIG. REF. 13	PART NUMBER	DESCRIPTION	O N A L L	QUANTITY PER ASSEMBLY			
				D	D2	D2B	D2C
1	71831* (**)	CYLINDER & HEAD ASSY., Plain		4			
	71832* (**)	CYLINDER & HEAD ASSY., Chrome		4			
	71837* (★)	CYLINDER & HEAD ASSY., Plain			4	4	4
	71838* (★)	CYLINDER & HEAD ASSY., Chrome			4	4	
2	66528**	SEAT, Intake valve		4			
	72057★	SEAT, Intake valve			4	4	4
3	72058	SEAT, Exhaust valve	4				
4	76943-S●	GUIDE, Valve intake, grooved (flangeless)	4				
5	66529-S●	GUIDE, Valve exhaust, grooved (flangeless)	4				
6	66796	INSERT, Sparkplug, 18-1.5MM	8				
7	31C-12	STUD, 5/16-18 x 1-1/2 long	8				
8	STD-700	ELBOW, 3/8 flared tube coupling, 90°	4				
9	66610	BUSHING, Rocker shaft	16				
10	LW-19298	RING, Guide retaining	8				
11	1102‡	PLUG, 1/8-27 NPT, Allen		4	4	4	
12	LW-19296	GASKET, Exhaust flange	4				
13	61259*	FLANGE, Exhaust, stainless				4	
14	STD-35	WASHER, 5/16 plain	8				
15	STD-475	WASHER, 5/16 lock, internal teeth	8				
16	STD-1410	NUT, 5/16-18 plain	8				

\* These parts are no longer available for purchase through Textron Lycoming.

\*\* Used with 6.50:1 compression pistons.

★ Used with 7.00:1 or 7.50:1 compression pistons.

● Item No. 10 valve guide ring P/N LW-19298 must be ordered separately when ordering this part. Refer to latest edition of Textron Lycoming Service Instruction No. 1256.

‡ Assemble in cylinder heads if no priming lines are installed.

Williamsport Plant

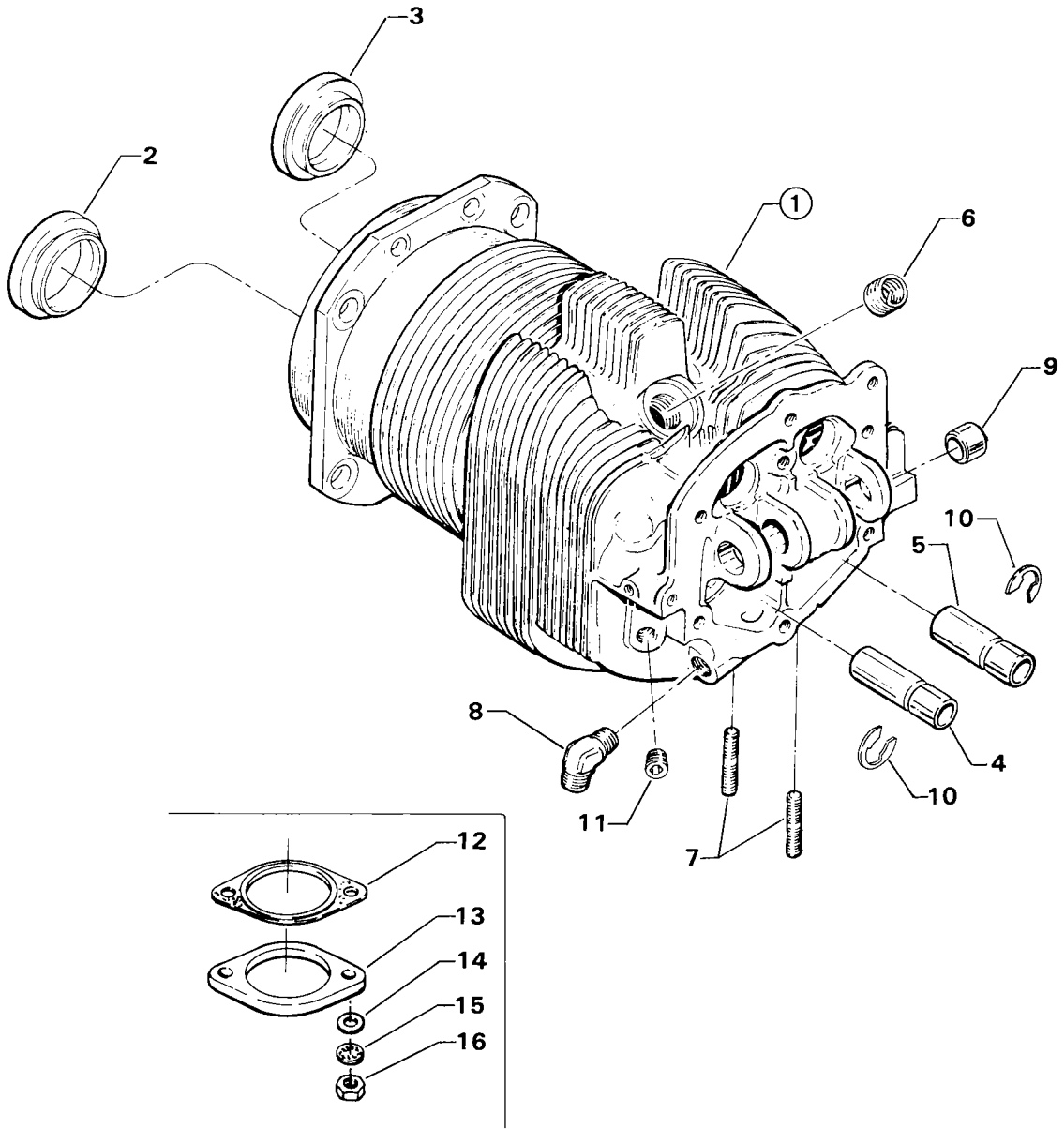

Figure 13. CYLINDER ASSEMBLY

Williamsport Plant

**CYLINDER, PISTON AND VALVE TRAIN  
VALVE ASSEMBLY**

FIG. REF. 14	PART NUMBER	DESCRIPTION	O N A L L	QUANTITY PER ASSEMBLY			
				D	D2	D2B	D2C
1	66429*	VALVE, Intake		4	4		
	73938**	VALVE, Intake			4	4	4
2	61631	VALVE, Exhaust	4				
3	LW-13323	SEAT, Valve spring, lower	8				
4	LW-11795	SPRING, Valve, auxiliary	8				
5	LW-11800	SPRING, Valve, outer	8				
6	LW-10077	SEAT, Valve spring	8				
7	60009	KEY, Valve	16				
8	78290**	PLUNGER ASSY., Hydraulic tappet			8	8	8
9	78524**	SOCKET, Push rod, hyd. tappet			8	8	8
10	LW-18661	SEAL, Shroud tube	16				
11	65006	TUBE, Push rod shroud	8				

- \* Used on engines employing solid tappets.
- \*\* Used on engines employing hydraulic tappets.

Williamsport Plant

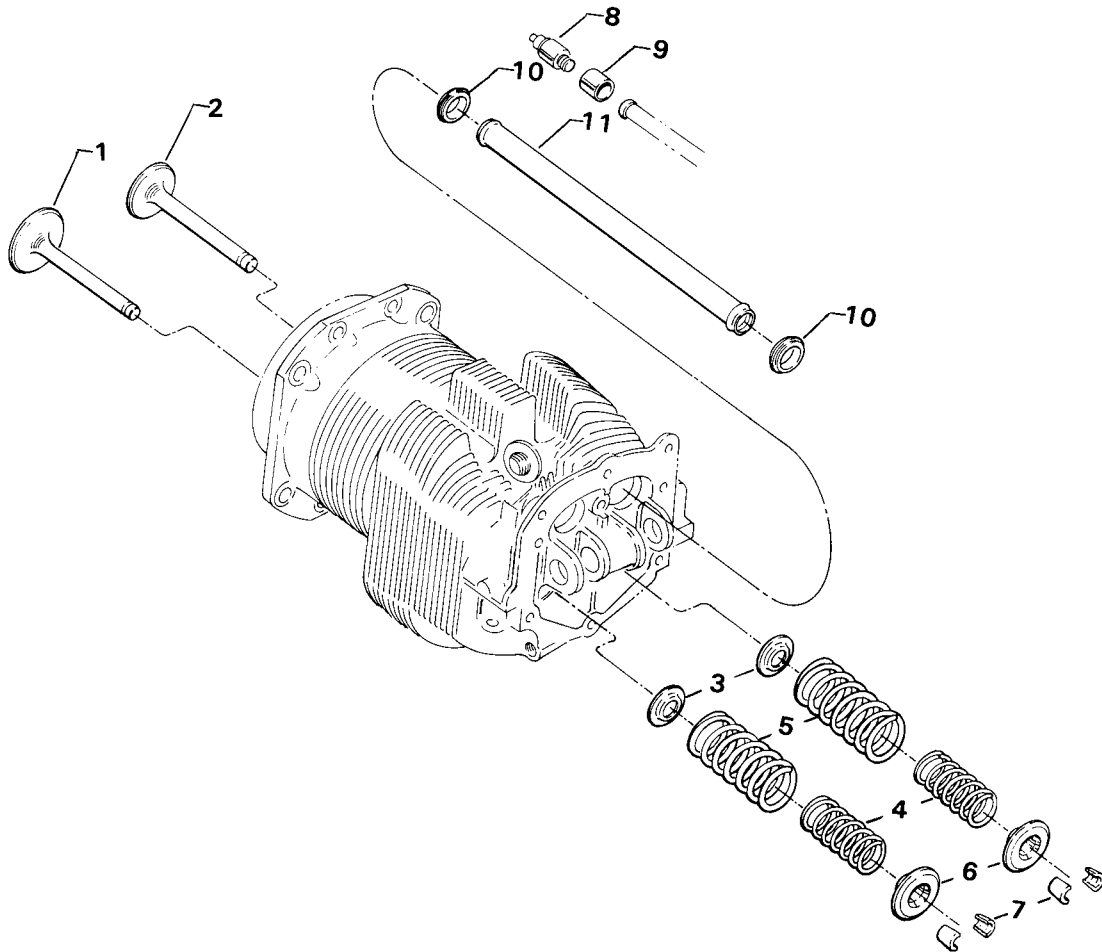

Figure 14. VALVE ASSEMBLY

Williamsport Plant

**CYLINDER, PISTON AND VALVE TRAIN  
CYLINDER RELATED PARTS**

FIG. REF. 15	PART NUMBER	DESCRIPTION	O N A L L	QUANTITY PER ASSEMBLY			
				D	D2	D2B	D2C
1	71481	RING, Oil seal, 3/32 dia. x 4-27/32 I.D.	4				
2	STD-2090	NUT, 1/2-20 plain	16				
3	383-B	NUT, 3/8-24 plain	16				
4	62156*	ROD ASSY., Push (a total of 8 required)		AR			
	73411*	ROD ASSY., Push (a total of 8 required)			AR	AR	AR
	73412*	ROD ASSY., Push (a total of 8 required)			AR	AR	AR
	73413*	ROD ASSY., Push (a total of 8 required)			AR	AR	AR
	73414*	ROD ASSY., Push (a total of 8 required)			AR	AR	AR
5	60831	ROCKER ASSY., Valve		8			
	68519	ROCKER ASSY., Valve			8	8	8
6	60398	BUSHING, Valve rocker	8				
7	LW-13790	SHAFT, Valve rocker	4				
8	LW-12892	THRUST BUTTON, Rocker shaft	8				
9	60025	SCREW, Valve adjusting		8			
10	STD-587	NUT, 9/16-18 x 5/32 thick		8			
11	75906	GASKET, Rocker box	4				
12	61247	COVER, Rocker box	4				
13	STD-1925	SCREW, 1/4-20 x 5/8 long, pan. hd., self-locking	24				
14	STD-684	NIPPLE, Straight, 3/8 I.D. hose	4				
15	STD-2180	HOSE, 3/8 I.D. x 1-13/16 long	4				
16	LW-15592-5-05	CLAMP	8				
17	60890	TUBE ASSY., Cyl. head oil drain, cyl. no. 1	1				
18	60821	TUBE ASSY., Cyl. head oil drain, cyl. no. 2	1				
19	60928	TUBE ASSY., Cyl. head oil drain, clys. no. 3 & 4	2				

\* See latest edition of Textron Lycoming Service Instruction No. 1060 for complete push rod application.

Williamsport Plant

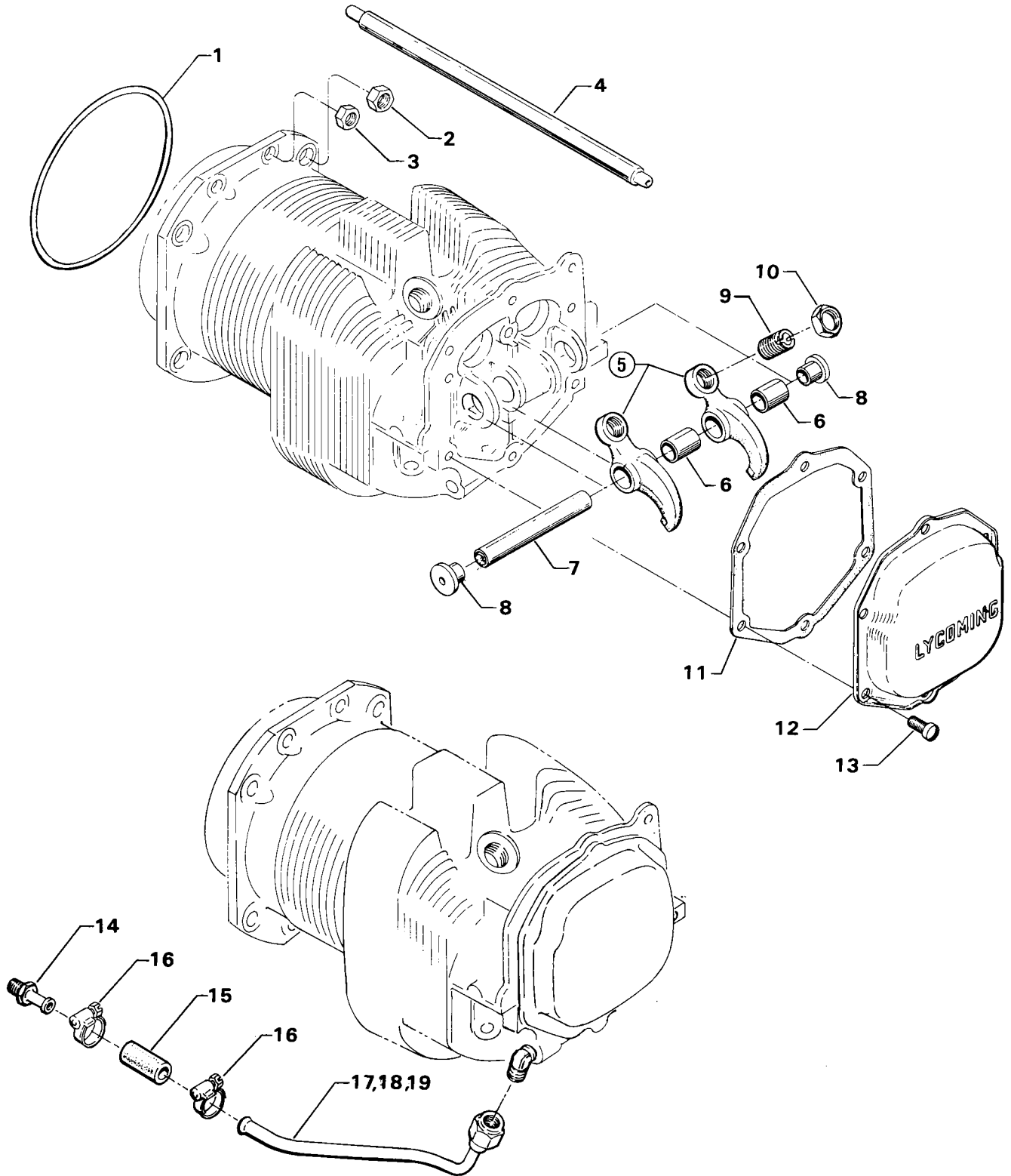

3170

**Figure 15. CYLINDER RELATED PARTS**

Williamsport Plant

**IGNITION SYSTEM**  
 MAGNETO, MAGNETO DRIVE AND SPARK PLUGS

FIG. REF. 16	PART NUMBER	DESCRIPTION	O N A L L	QUANTITY PER ASSEMBLY			
				D	D2	D2B	D2C
1	61665	GEAR, Magneto, impulse coupling		1	1	1	
2	68C19622	GEAR, Magneto, retard breaker					1
3	61163	GEAR, Magneto	1				
4	62224	GASKET, Magneto adapter & magneto		3	3	3	2
5	LW-12706	ADAPTER, Magneto, impulse coupling		1	1	1	
6	LW-51360-29	MAGNETO, S4LN-20		1	1	1	
	LW-51360-37	MAGNETO, Impulse coupling, S4LN-21		1	1	1	
	LW-163045-3	MAGNETO, S4LN-204					1
	LW-163005-2	MAGNETO, Retard breaker, S4LN-200					1
7	STD-1727	WASHER, Plain, 3/4 O.D. x 21/64 I.D. x 1/8 thick	4				
8	STD-475	WASHER, 5/16 lock, internal teeth	4				
9	STD-1410	NUT, 5/16-18 plain	4				
10	1182-B3 *	SPARK PLUG, Champion (REM-40E)	8				
	1182-F3 *	SPARK PLUG, SL Auburn (SR-88)	8				
	1182-V4 *	SPARK PLUG, Auto Lite (SH-15R)	8				
11	LW-52305-1	KIT ASSY., Magneto ground terminal		2	2	2	
	LW-157209	KIT, Magneto ground terminal					2
12	LW-157208	KIT, Magneto retard terminal					1

\* See latest edition of Textron Lycoming Service Instruction No. 1042 for complete listing of all approved spark plugs.

Williamsport Plant

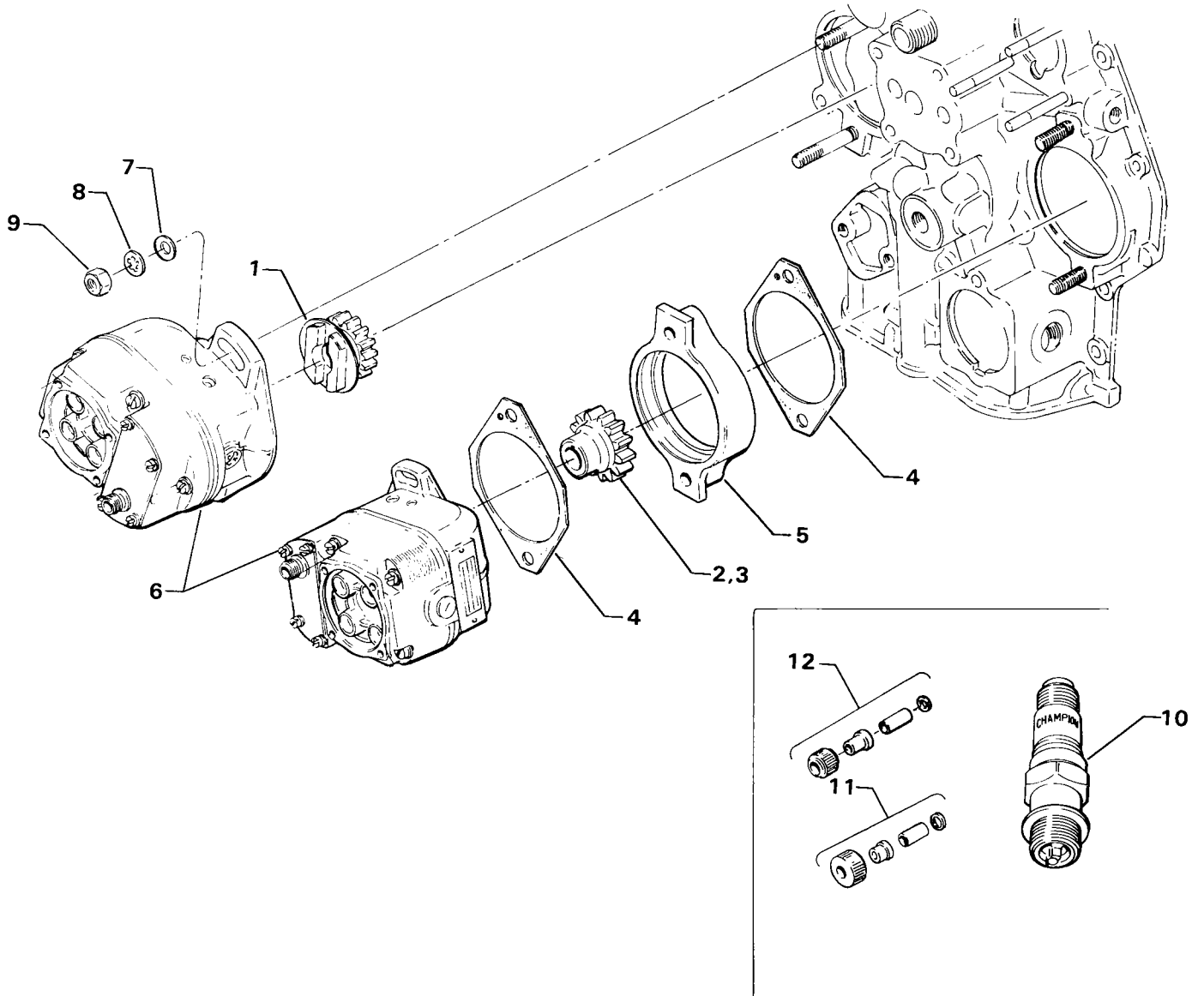

3171

Figure 16. MAGNETO, MAGNETO DRIVE AND SPARK PLUGS

Williamsport Plant

**ELECTRICAL COMPONENTS**  
ALTERNATOR ASSEMBLY AND BELT

FIG. REF. 17	PART NUMBER	DESCRIPTION	O N A L L	QUANTITY PER ASSEMBLY			
				D	D2	D2B	D2C
1	LW-14371	ALTERNATOR ASSY., 12 volt, 60 amp. Prestolite	1				
2	LW-14313	ALTERNATOR, (ALY-8420-LS)	1				
3	36B19484	PULLEY, Alternator	1				
4	76026	BELT, Alternator drive	1				

NOTE

See latest edition of Textron Lycoming Service Instruction No. 1154 for complete listing of FAA approved starters, generators, alternators, regulators and relays.

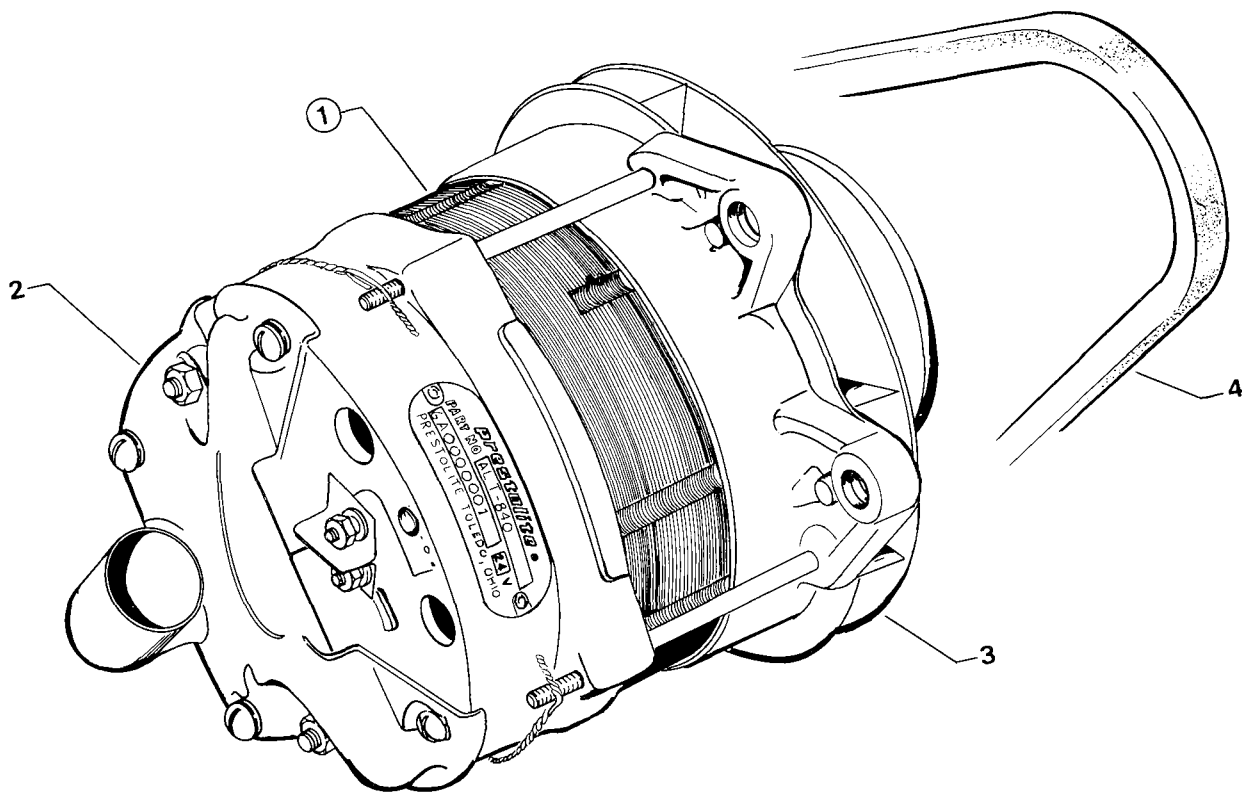

Figure 17. ALTERNATOR ASSEMBLY AND BELT

Williamsport Plant

**ELECTRICAL COMPONENTS**  
STARTER MOTOR AND ATTACHING PARTS

FIG. REF. 18	PART NUMBER	DESCRIPTION	O N A L L	QUANTITY PER ASSEMBLY			
				D	D2	D2B	D2C
1	76210	STARTER, 12 volt (no reduction, 10/12 pitch pinion) (MZ-4204)		1	1	1	1
	LW-15571	STARTER, 12 volt (3.38:1 internal reduction, 12/14 pitch pinion) (MZ-4222)		1	1	1	
	69953	STARTER, 24 volt (no reduction, 10/12 pitch pinion) (1109669)		1	1	1	
2	STD-35	WASHER, 5/16 plain	4				
3	STD-475	WASHER, 5/16 lock, internal teeth	4				
4	LW-31-1.16	BOLT, 5/16-18 x 1-5/32 long, hex. hd.	1				
5	STD-1410	NUT, 5/16-18 plain	3				
6	LW-12083	SWITCH, Magnetic (SAZ-4201E-1)	1				

NOTE

See latest edition of Textron Lycoming Service Instruction No. 1154 for complete listing of FAA approved starters, generators, alternators, regulators and relays.

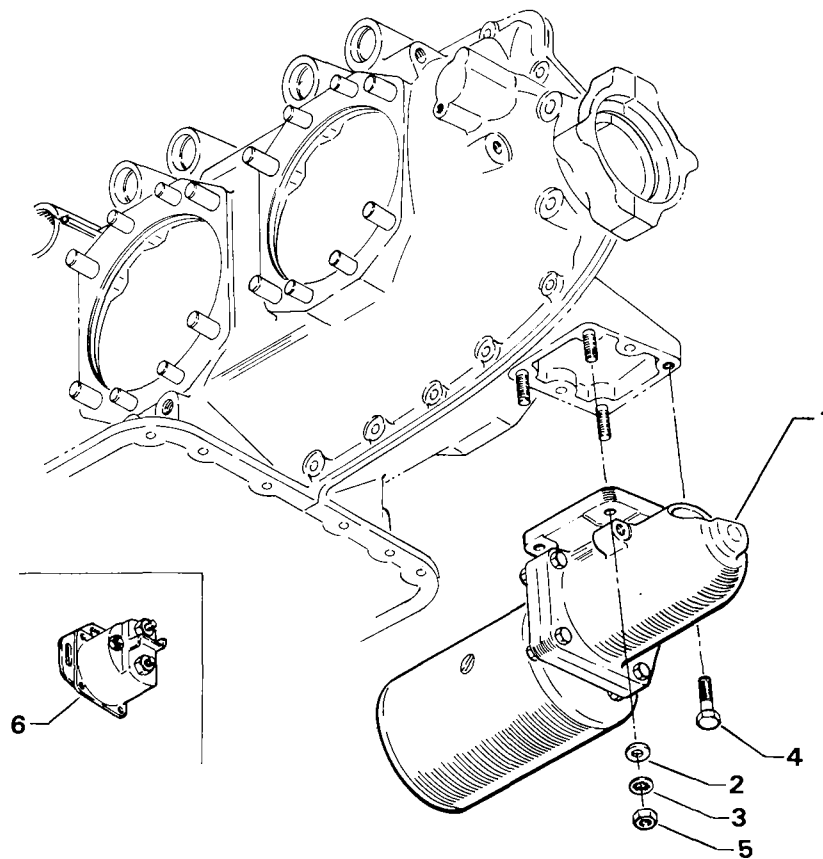

Figure 18. STARTER MOTOR AND ATTACHING PARTS

Williamsport Plant

**ELECTRICAL COMPONENTS**  
ALTERNATOR MOUNTING AND ATTACHING PARTS

FIG. REF. 19	PART NUMBER	DESCRIPTION	O N A L L	QUANTITY PER ASSEMBLY			
				D	D2	D2B	D2C
1	78158	BRACKET, Alternator	1				
2	STD-8	WASHER, 1/4 plain	1				
3	STD-160	WASHER, 1/4 lock, internal teeth	3				
4	LW-25-1.75	BOLT, 1/4-20 x 1-3/4 long, hex. hd.	1				
5	LW-25-1.25	BOLT, 1/4-20 x 1-1/4 long, hex. hd.	2				
6	STD-1411	NUT, 1/4-20 plain	1				
7	75380	LINK, Alternator adjusting	1				
8	STD-35	WASHER, 5/16 plain	1				
9	LW-31H0.75	BOLT, 5/16-18 x 3/4 long, hex. hd.	1				
10	STD-1727	WASHER, 3/4 O.D. x 11/32 I.D. x 1/8 thick	1				
11	LW-31H0.75	BOLT, 5/16-18 x 3/4 long, hex. hd.	1				
12	STD-690	WASHER, 13/16 O.D. x 25/64 I.D. x 1/16 thick	1				
13	AN6-14	BOLT, 3/8-24 x 1-37/64 long, hex. hd., dr. end	1				
14	STD-690	WASHER, 13/16 O.D. x 25/64 I.D. x 1/16 thick	AR				
15	STD-872	NUT, 3/8-24 slotted	1				
16	STD-713	PIN, Cotter, 3/32 dia. x 3/4 long	1				
17	AN6-13	BOLT, 3/8-24 x 1-29/64 long, hex. hd., dr. end	1				
18	76534	SHIM, 1-1/8 O.D. x 13/32 I.D. x .005 thick	AR				
19	STD-690	WASHER, 13/16 O.D. x 25/64 I.D. x 1/16 thick	AR				
20	STD-872	NUT, 3/8-24 slotted	1				
21	STD-713	PIN, Cotter, 3/32 dia. x 3/4 long	1				
22	74323	STRUT, Alternator support	1				
23	LW-31H0.75	BOLT, 5/16-18 x 3/4 long, hex. hd.	1				

Williamsport Plant

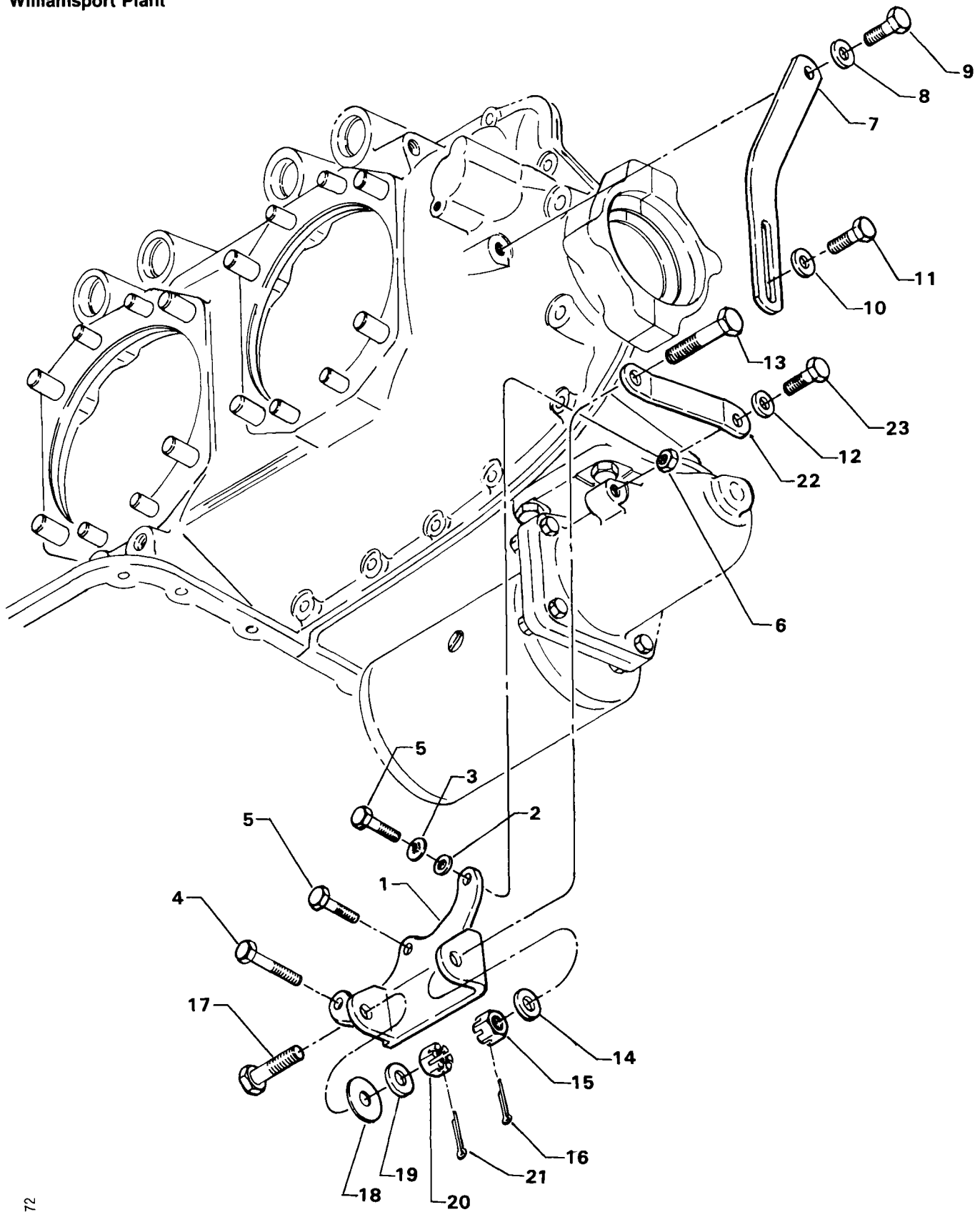

3172

**Figure 19. ALTERNATOR MOUNTING AND ATTACHING PARTS**

Williamsport Plant

**OIL SUMP AND INDUCTION SYSTEM**  
**OIL SUMP ASSEMBLY AND OIL SUCTION SCREEN**

FIG. REF. 20	PART NUMBER	DESCRIPTION	O N A L L	QUANTITY PER ASSEMBLY			
				D	D2	D2B	D2C
1	LW-13353	GASKET, Oil sump	1				
2	LW-15688	SUMP ASSY., Oil	1				
3	61376	CONNECTION, Intake pipe, front	2				
4	61377	CONNECTION, Intake pipe, rear	2				
5	25C-12	STUD, 1/4-20 x 1-1/2 long	4				
6	STD-551	PLUG, 1/2-14 NPT, sq. hd., drilled	1				
7	STD-8	WASHER, 1/4 plain	32				
8	STD-160	WASHER, 1/4 lock, internal teeth	20				
9	LW-25-0.94	BOLT, 1/4-20 x 15/16 long, hex. hd.	18				
10	STD-1411	NUT, 1/4-20 plain	14				
11	60820	GASKET, Oil suction tube flange	1				
12	61381	TUBE ASSY., Oil suction	1				
13	STD-1227	WASHER, 1/4 plain	2				
14	STD-1433	BOLT, 1/4-20 x 1-1/2 long, hex. hd., drilled	2				
15	STD-8	WASHER, 1/4 plain (max. 4)	AR				
16	STD-1409	NUT, 1/4-20 slotted shear	2				
17	STD-68	PIN, 1/16 dia. x 1/2 long, cotter	2				
18	61378	SCREEN, Oil suction	1				
19	STD-1045	GASKET, 1/8 I.D. 1-1/2 O.D. x 3/32 annular	1				
20	61358	PLUG, 5/32 hex. hd. x 1-1/4-12 thd.	1				

Williamsport Plant

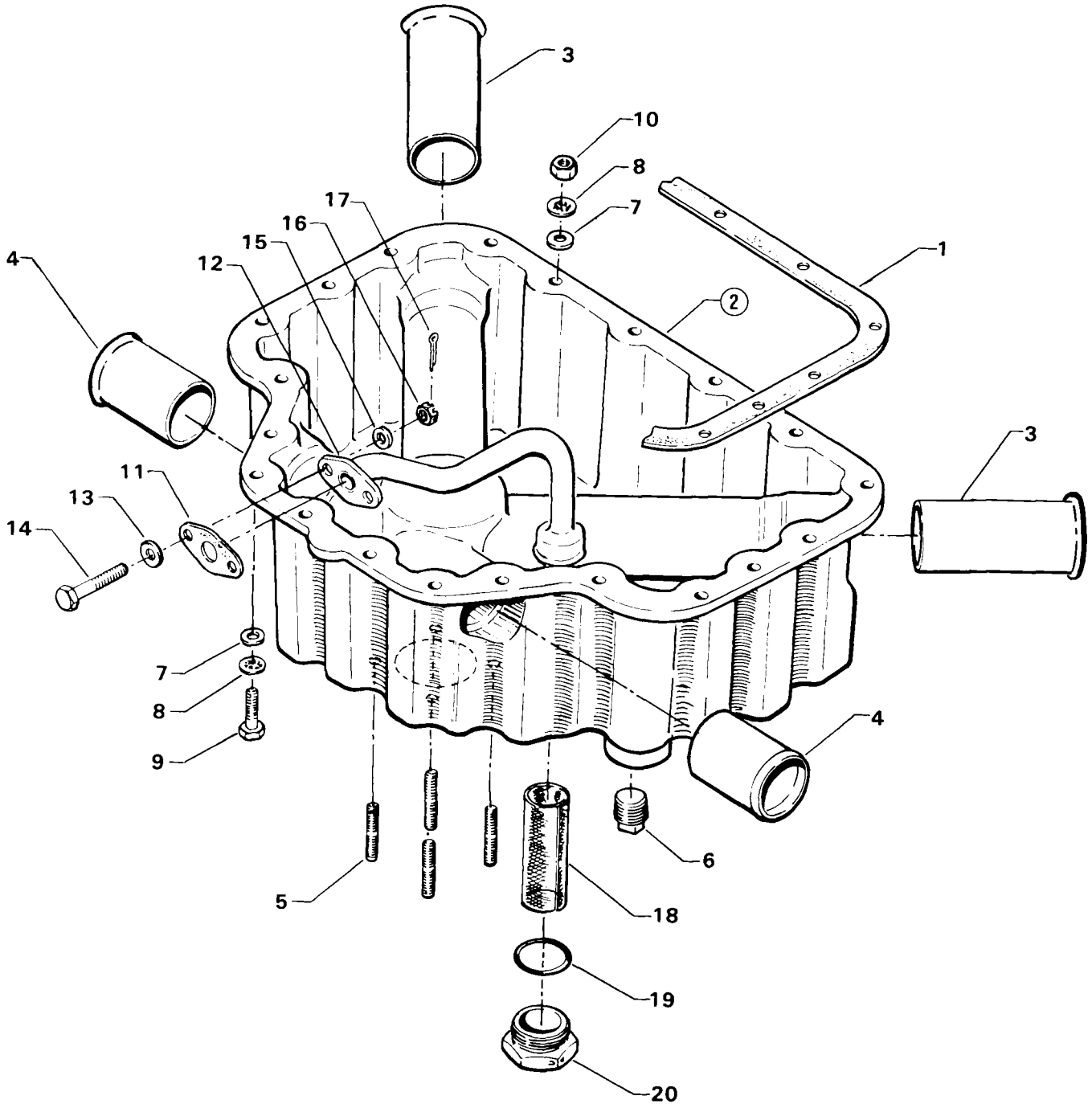

Figure 20. OIL SUMP ASSEMBLY AND OIL SUCTION SCREEN

Williamsport Plant

**OIL SUMP AND INDUCTION SYSTEM  
INTAKE PIPE ASSEMBLY**

FIG. REF. 21	PART NUMBER	DESCRIPTION	O N A L L	QUANTITY PER ASSEMBLY			
				D	D2	D2B	D2C
1	LW-16728	PIPE, Intake, cylinders no. 1 & 2	2				
2	LW-16730	PIPE, Intake, cylinder no. 3	1				
3	LW-16729	PIPE, Intake, cylinder no. 4	1				
4	STD-1196	HOSE, 1-1/2 I.D. x 1-7/8 O.D. x 1-1/2 long	4				
5	LW-15592-8-24	CLAMP, Hose, 1-3/4 I.D. x 9/16 wide	8				
6	71973	GASKET, 2 bolt flange, 1-3/4 I.D.	4				
7	73346	FLANGE, Intake pipe, upper	4				
8	STD-8	WASHER, 1/4 plain	8				
9	STD-160	WASHER, 1/4 lock, internal teeth	8				
10	LW-25-1.25	BOLT, 1/4-20 x 1-1/4 long, hex. hd.	8				

Williamsport Plant

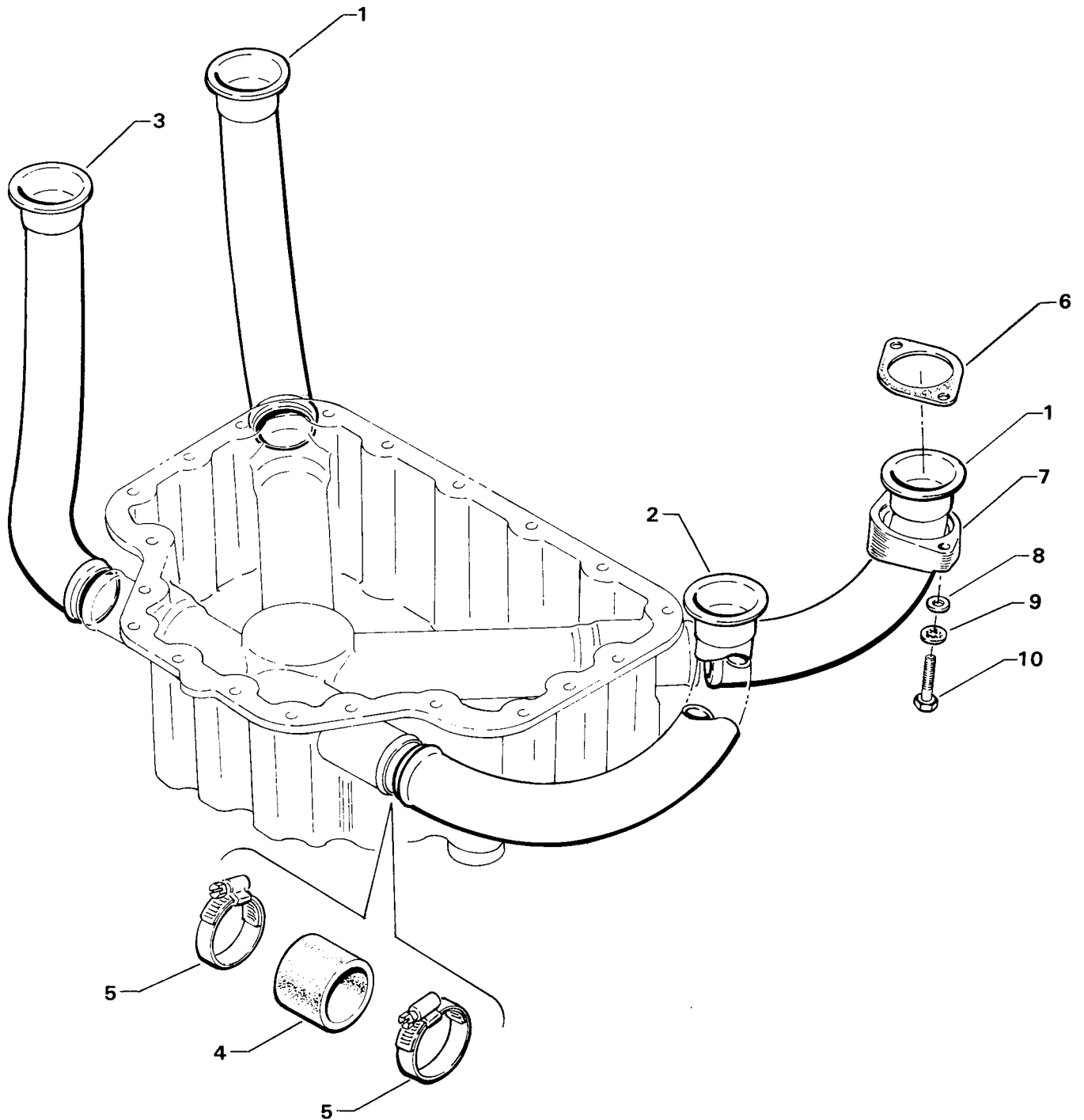

2679

Figure 21. INTAKE PIPE ASSEMBLY

Williamsport Plant

**OIL SUMP AND INDUCTION SYSTEM  
CARBURETOR ASSEMBLY**

FIG. REF. 22	PART NUMBER	DESCRIPTION	O N A L L	QUANTITY PER ASSEMBLY			
				D	D2	D2B	D2C
1	60592	GASKET, Carburetor	1				
2	62289*	CARBURETOR, Marvel-Schebler MA-3SPA (10-3346-1)		1			
	62830*	CARBURETOR, Marvel-Schebler MA-3SPA (10-3565-1)			1	1	1
3	STD-8	WASHER, 1/4 plain	4				
4	STD-160	WASHER, 1/4 lock, internal teeth	4				
5	STD-1411	NUT, 1/4-20 plain	4				

\* These parts are no longer available for purchase through Textron Lycoming.

Williamsport Plant

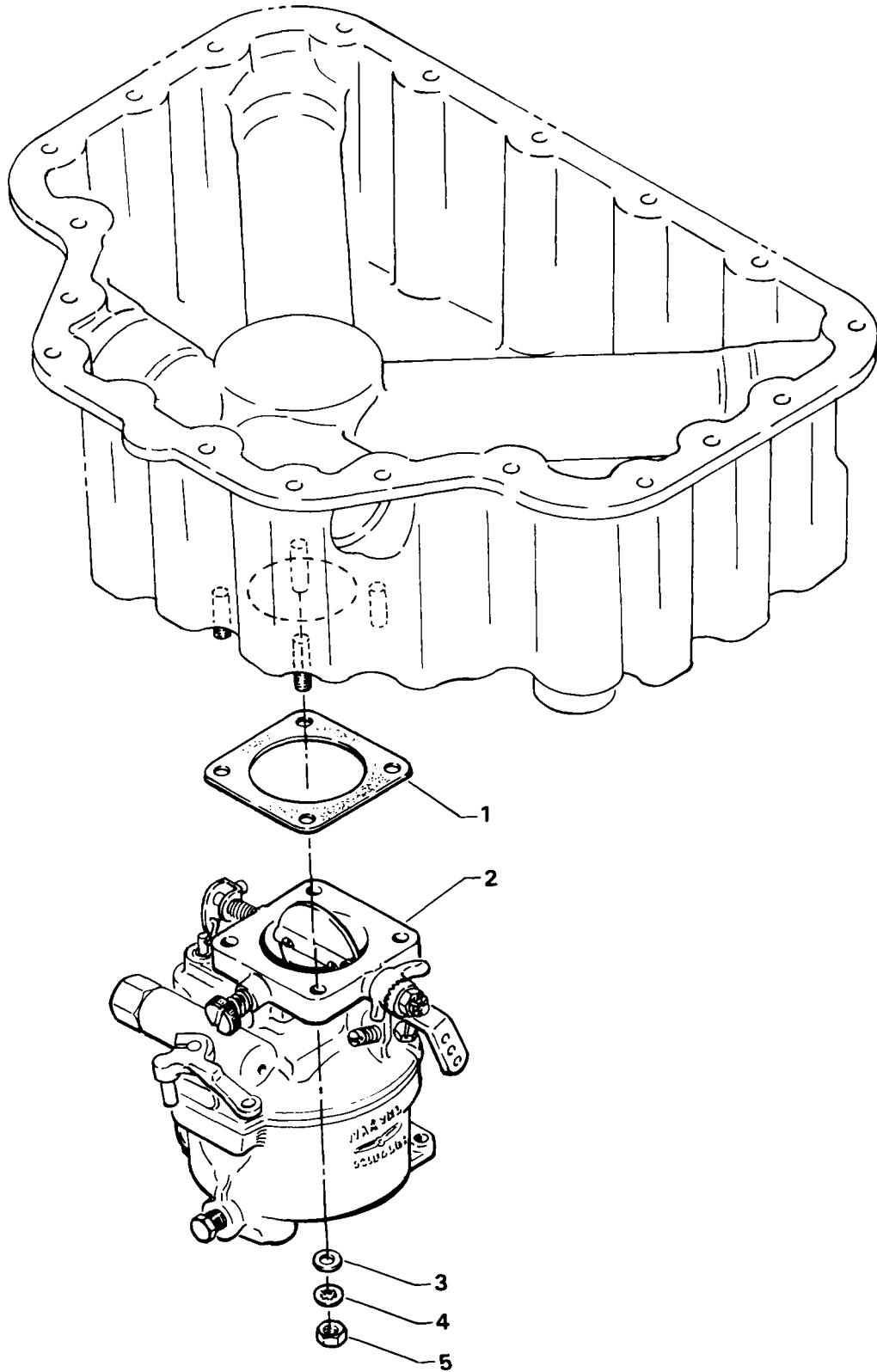

2716

Figure 22. CARBURETOR ASSEMBLY

Williamsport Plant

**OIL SUMP AND INDUCTION SYSTEM  
PRIMING SYSTEM**

FIG. REF. 23	PART NUMBER	DESCRIPTION	O N A L L	QUANTITY PER ASSEMBLY			
				D	D2	D2B	D2C
1	LW-12098-0-170	TUBE ASSY., Primer, cyls. 1 & 2			2	2	2
2	LW-12098-0-120	TUBE ASSY., Primer, cyls. 3 & 4			2	2	2
3	LW-12098-0-100	TUBE ASSY., Primer, Intermediate			2	2	2
4	LW-16266-25-13	CLIP, 3/16 I.D. for 1/4 dia. screw, cushion type			4	4	4
5	LW-18959-150-25	CLAMP, 1-1/2 I.D. with 1/4 dia. offset			4	4	4
6	STD-553	SCREW, No. 6-32 x 1/2 long, rd. hd.			4	4	4
7	AN365-632A	NUT, No. 6-32 self-locking			4	4	4
8	STD-853	TEE, Union, 1/8 tube			3	3	3
9	74225	NIPPLE ASSY., Primer			4	4	4

Williamsport Plant

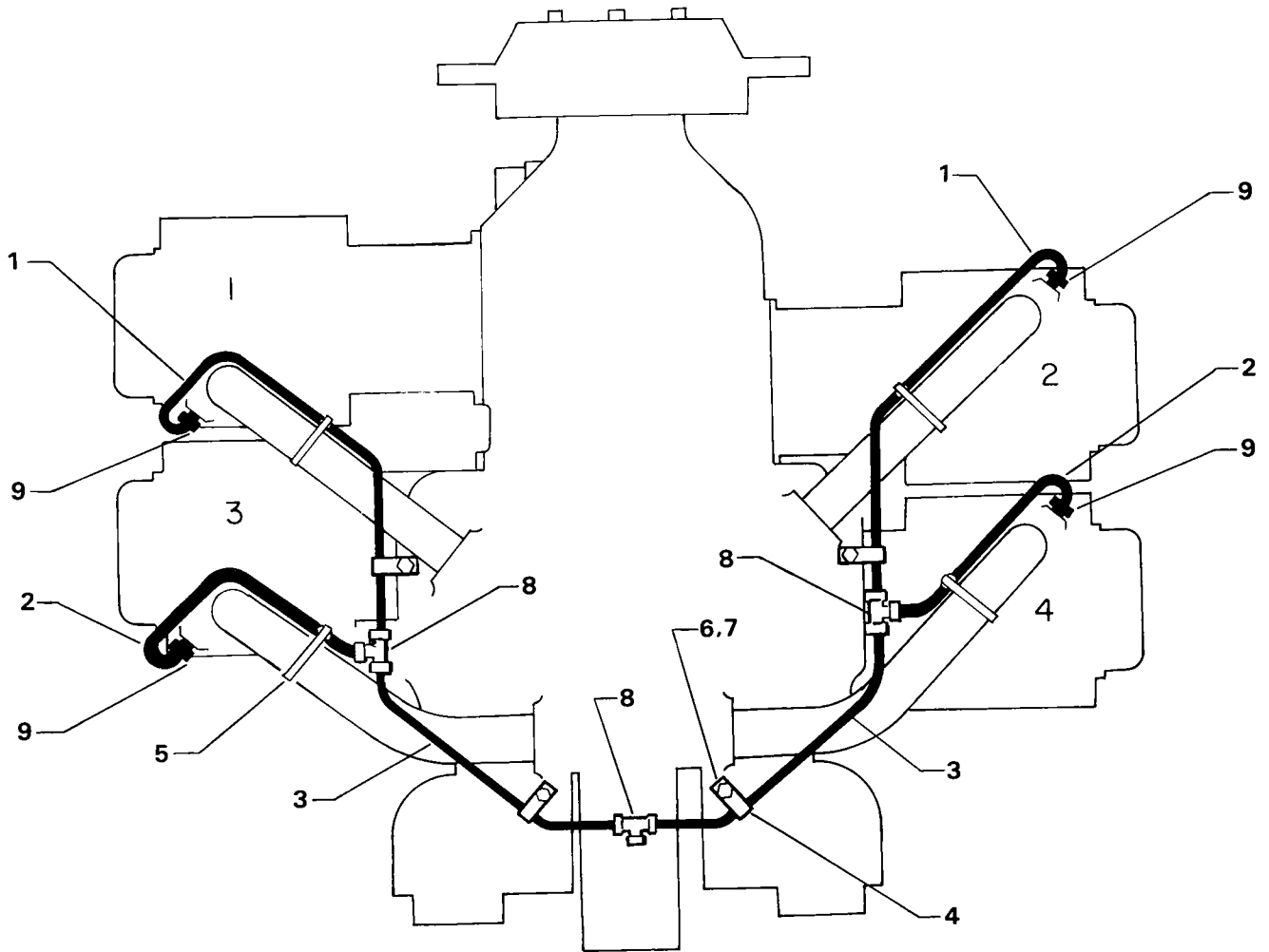

3169

Figure 23. PRIMING SYSTEM

Williamsport Plant

**SERVICE KIT SECTION****SEAL AND GASKET SET**

Part No.	Part Name	Qty.
69371-1	SEAL AND GASKET SET	1
MS29512-6	SEAL	1
06E19769-1.00	GASKET	1
STD-2217	SEAL, Oil	1
STD-213	SEAL	1
STD-294	GASKET, Annular	2
STD-548	SEAL, Oil	1
STD-1006	RING, Oil seal	1
STD-1045	GASKET, Annular	2
STD-2072	"O" RING	1
1691-C	GASKET	1
8313	GASKET, Vacuum pump	2
60096	GASKET, Fuel pump	1
60592	GASKET, Carburetor	1
60820	GASKET, Oil suction tube flange	1
61173	GASKET, Oil pressure housing	1
61183	GASKET, Accessory adapter	1
61531	GASKET, Hydraulic valve	1
62224	GASKET, Magneto adapter	4
LW-19296	GASKET, Exhaust flange	4
66224	GASKET, Carburetor	2
68315	GASKET, Accessory drive adapter	1
69164	GASKET	1
69345	SPACER	4
69551	GASKET, Accessory pad cover	1
69720	GASKET, Dual accessory drive cover	1
69827	GASKET, Governor spacer	1
70310	SEAL, Shroud tube	8
70455	GASKET	1
71481	RING, Oil seal	4
71973	GASKET, Intake flange	4
72053	GASKET, Governor drive	2
72059	GASKET	1
72075	SEAL, Oil	6
72078	LOCKPLATE, Cam gear	2
72091	RING, Oil seal	2
72312	RING, Oil seal	1
72829	LOCKPLATE	1
73383	LOCKPLATE	2
73817	LOCKPLATE, Crankshaft idler gear shaft	2
73818	GASKET, Accessory housing	1
74065	RING, Oil level gage seal	1
74068	RING, Oil level gage seal	1
74524	RING, Oil seal	1
75906	GASKET, Rocker box cover	4
76510	GASKET	1
76940	SEAL, Crankshaft oil	1
LW-12272	LOCKPLATE, Shroud tube	4
LW-12681	GASKET, Magneto	2
LW-12795	GASKET	1
LW-13353	GASKET, Oil sump	1
LW-13792	SEAL, Crankshaft oil	1
LW-14260	SEAL, Tachometer shaft	1
LW-14995	SPRING	4
LW-18639	LOCKPLATE, Crankshaft gear	1
LW-18661	SEAL, Shroud tube	16

Williamsport Plant

**SERVICE KIT SECTION****CYLINDER, PISTON AND RING ASSEMBLY**

Part No.	Part Name	Qty.
69543*	CYLINDER, PISTON AND RING ASSEMBLY	1
71838*	CYLINDER AND HEAD ASSEMBLY	1
73938	VALVE, Intake	1
66531	VALVE, Exhaust	1
65441	SEAT, Valve spring, lower	2
65567*	SPRING, Valve auxiliary	2
65427*	SPRING, Valve outer	2
68327*	SEAT, Valve spring	2
60009	KEY, Valve	4
1102	PLUG, 1/8 pipe x 3/8 long, socket	1
68519	ROCKER ASSY., Valve	2
71481	SEAL, Cylinder base oil	1
60053*	SEAL, Shroud tube	4
60401*	SHAFT, Valve rocker	1
75906	GASKET, Rocker box cover	1
61247	COVER, Rocker box	1
STD-1925	SCREW, 1/4-20 x 5/8 long, fill. hd.	6
69841	PISTON	1
60403	PIN, Piston	1
72434	PLUG, Piston pin	2
71555*	RING, Top & 2nd compression	2
68338	RING, Oil regulating, expander type	1

\* These parts are no longer available for purchase through Textron Lycoming.

Williamsport Plant

**SERVICE KIT SECTION****CYLINDER, PISTON AND RING ASSEMBLY**

Part No.	Part Name	Qty.
69674*	CYLINDER, PISTON AND RING ASSEMBLY	1
71837*	CYLINDER AND HEAD ASSEMBLY	1
73938	VALVE, Intake	1
66531	VALVE, Exhaust	1
65441	SEAT, Valve spring lower	2
65567*	SPRING, Valve auxiliary	2
65427*	SPRING, Valve outer	2
68327*	SEAT, Valve spring	2
60009	KEY, Valve	4
1102	PLUG, 1/8 pipe x 3/8 long, socket	1
68519	ROCKER ASSY., Valve	2
60401*	SHAFT, Valve rocker	1
75906	GASKET, Rocker box cover	1
61247	COVER, Rocker box	1
STD-1925	SCREW, 1/4-20 x 5/8 long, fill. hd.	6
69841	PISTON	1
60403	PIN, Piston	1
71481	SEAL, Cylinder base oil	1
60053*	SEAL, Shroud tube	4
60311	PLUG, Piston pin	2
62916	RING, Top compression	2
69401	RING, Piston, oil regulating, expander type	1

\* These parts are no longer available for purchase through Textron Lycoming.

Williamsport Plant

**SERVICE KIT SECTION****CYLINDER, PISTON AND RING ASSEMBLY**

Part No.	Part Name	Qty.
71199*	CYLINDER, PISTON AND RING ASSEMBLY	1
71837*	CYLINDER AND HEAD ASSEMBLY	1
73938	VALVE, Intake	1
66531	VALVE, Exhaust	1
65441	SEAT, Valve spring lower	2
65567*	SPRING, Valve auxiliary	2
65427*	SPRING, Valve outer	2
68327*	SEAT, Valve spring	2
60009	KEY, Valve	4
1102	PLUG, 1/8 pipe x 3/8 long, socket	1
68519	ROCKER ASSY., Valve	2
60401*	SHAFT, Valve rocker	1
75906	GASKET, Rocker box cover	1
61247	COVER, Rocker box	1
STD-1925	SCREW, 1/4-20 x 5/8 long, fill. hd.	6
70396	PISTON	1
60403	PIN, Piston	1
71481	SEAL, Cylinder base oil	1
60053*	SEAL, Shroud tube	4
60311	PLUG, Piston pin	2
62916	RING, Top compression	1
68115	RING, 2nd compression	1
68338	RING, Oil regulating, expander type	1

\* These parts are no longer available for purchase through Textron Lycoming.

Williamsport Plant

**SERVICE KIT SECTION****CYLINDER, PISTON AND RING ASSEMBLY**

Part No.	Part Name	Qty.
71984*	CYLINDER, PISTON AND RING ASSEMBLY	1
71831*	CYLINDER AND HEAD ASSEMBLY	1
STD-587	NUT	2
STD-1925	SCREW, 1/4-20 x 5/8 long, fill. hd.	6
1102	PLUG, 1/8 pipe x 3/8 long, socket	1
60009	KEY, Valve	4
60025	SCREW, Valve adjusting	2
60311	PLUG, Piston pin	2
60401*	SHAFT, Valve rocker	1
60403	PIN, Piston	1
60831	ROCKER ASSY., Valve	2
75906	GASKET, Rocker box cover	1
61247	COVER, Rocker box	1
62916	RING, Piston top compression	2
65427*	SPRING, Valve, outer	2
71481	SEAL, Cylinder base oil	1
60053*	SEAL, Shroud tube	4
65441	SEAT, Valve spring, lower	2
65567*	SPRING, Valve, auxiliary	2
66429	VALVE, Intake	1
66531	VALVE, Exhaust	1
68327*	SEAT, Valve spring	2
69401	RING, Piston, oil regulating	1
69958	PISTON	1

\* These parts are no longer available for purchase through Textron Lycoming.

Williamsport Plant

**SERVICE KIT SECTION****CYLINDER, PISTON AND RING ASSEMBLY**

Part No.	Part Name	Qty.
71985*	CYLINDER, PISTON AND RING ASSEMBLY	1
71832*	CYLINDER AND HEAD ASSEMBLY	1
STD-587	NUT	2
STD-1925	SCREW, 1/4-20 x 5/8 long, fill. hd.	6
1102	PLUG, 1/8 pipe x 3/8 long, socket	1
60009	KEY, Valve	4
60025	SCREW, Valve adjusting	2
72434	PLUG, Piston pin	2
60401*	SHAFT, Valve rocker	1
60403	PIN, Piston	1
60831	ROCKER ASSY., Valve	2
75906	GASKET, Rocker box cover	1
61247	COVER, Rocker box	1
65427*	SPRING, Valve, outer	2
65441	SEAT, Valve spring, lower	2
71481	SEAL, Cylinder base oil	1
60053*	SEAL, Shroud tube	4
65567*	SPRING, Valve, auxiliary	2
66429	VALVE, Intake	1
66531	VALVE, Exhaust	1
71555*	RING, Piston compression	2
68327*	SEAT, Valve spring	2
68338	RING, Piston, oil regulating, expander type	1
69958	PISTON	1

\* These parts are no longer available for purchase through Textron Lycoming.

Williamsport Plant

**SERVICE KIT SECTION****CYLINDER, PISTON AND RING ASSEMBLY**

Part No.	Part Name	Qty.
75326*	CYLINDER, PISTON AND RING ASSEMBLY	1
71838*	CYLINDER AND HEAD ASSEMBLY	1
73938	VALVE, Intake	1
66531	VALVE, Exhaust	1
65441	SEAT, Valve spring, lower	2
65567*	SPRING, Valve auxiliary	2
65427*	SPRING, Valve outer	2
68327*	SEAT, Valve spring	2
60009	KEY, Valve	4
1102	PLUG, 1/8 pipe x 3/8 long, socket	1
68519	ROCKER ASSY., Valve	2
71481	SEAL, Cylinder base oil	1
60053*	SEAL, Shroud tube	4
60401*	SHAFT, Valve rocker	1
75906	GASKET, Rocker box cover	1
61247	COVER, Rocker box	1
STD-1826	SCREW, 1/4-20 x 5/8 long, fill. hd.	6
70396	PISTON	1
60403	PIN, Piston	1
72434	PLUG, Piston pin	2
71555*	RING, Top & 2nd compression	2
68338	RING, Oil regulating, expander type	1

\* These parts are no longer available for purchase through Textron Lycoming.

**Williamsport Plant****NUMERICAL INDEX**

PART NO.	PART NAME	PAGE NO.	PART NO.	PART NAME	PAGE NO.
AN6-13	Bolt	5-3	LW-157208	Kit	4-1
AN6-14	Bolt	5-3	LW-157209	Kit	4-1
AN6-21	Boit	1-11	LW-16266-25-13	Clip	6-7
AN6-34A	Bolt	1-11	LW-163005-2	Magneto	4-1
AN365-632A	Nut	6-7	LW-163045-3	Magneto	4-1
LW-25-0.63	Bolt	1-9	LW-16728	Pipe	6-3
LW-25-0.94	Bolt	1-1	LW-16729	Pipe	6-3
LW-25-0.94	Bolt	2-3	LW-16730	Pipe	6-3
LW-25-0.94	Bolt	6-1	LW-18639	Lockplate	1-7
LW-25-1.13	Bolt	1-11	LW-18661	Seal	3-5
LW-25-1.25	Bolt	5-3	LW-18667	Pin	1-9
LW-25-1.25	Bolt	6-3	LW-18959-150-25	Clamp	6-7
LW-25-1.50	Bolt	1-11	LW-19296	Gasket	3-3
LW-25-1.50	Bolt	2-3	LW-19298	Ring	3-3
LW-25S1.50	Bolt	1-11	LW-51360-25	Magneto	4-1
LW-25-1.75	Bolt	1-11	LW-51360-29	Magneto	4-1
LW-25-1.75	Bolt	5-3	LW-51360-37	Magneto	4-1
LW-31-1.16	Bolt	5-2	LW-52305-1	Kit Assy.	4-1
LW-31H0.75	Bolt	5-3	STD-8	Washer	1-1
LW-38-0.75	Bolt	2-5	STD-8	Washer	1-11
LW-10070	Crankcase Assy.	1-1	STD-8	Washer	2-3
LW-10071	Crankcase Assy.	1-1	STD-8	Washer	2-6
LW-10077	Seat	3-5	STD-8	Washer	2-7
LW-11713	Spring	1-5	STD-8	Washer	5-3
LW-11795	Spring	3-5	STD-8	Washer	6-1
LW-11800	Spring	3-5	STD-8	Washer	6-3
LW-11997	Seal	1-5	STD-8	Washer	6-5
LW-12083	Switch	5-2	STD-33	Washer	1-7
LW-12098-0-100	Tube Assy.	6-7	STD-33	Washer	1-11
LW-12098-0-120	Tube Assy.	6-7	STD-33	Washer	2-5
LW-12098-0-170	Tube Assy.	6-7	STD-35	Washer	2-3
LW-12186	Nut	3-1	STD-35	Washer	3-3
LW-12706	Adapter	4-1	STD-35	Washer	5-2
LW-12892	Thrust Button	3-7	STD-35	Washer	5-3
LW-13323	Seat	3-5	STD-43	Nut	1-1
LW-13353	Gasket	6-1	STD-68	Pin	1-1
LW-13790	Shaft	3-7	STD-68	Pin	6-1
LW-13792	Seal	1-5	STD-131	Screw	1-1
LW-13883	Ring	3-1	STD-160	Washer	1-1
LW-13923	Bushing	3-1	STD-160	Washer	1-11
LW-14260	Seal	1-1	STD-160	Washer	2-3
LW-14260	Seal	2-3	STD-160	Washer	2-7
LW-14313	Alternator	5-1	STD-160	Washer	5-3
LW-14371	Alternator Assy.	5-1	STD-160	Washer	6-1
LW-14759	Gage Assy.	1-3	STD-160	Washer	6-3
LW-15472	Fuel Pump	2-5	STD-160	Washer	6-5
LW-15571	Starter	5-2	STD-294	Gasket	2-6
LW-15592-5-05	Clamp	3-7	STD-425	Washer	1-5
LW-15592-8-24	Clamp	6-3	STD-475	Washer	3-3
LW-15688	Sump Assy.	6-1	STD-475	Washer	4-1

Williamsport Plant

**NUMERICAL INDEX (Cont.)**

PART NO.	PART NAME	PAGE NO.	PART NO.	PART NAME	PAGE NO.
STD-475	Washer	5-2	STD-2217	Oil Seal	2-7
STD-514	Dowel	1-1	25C-12	Stud	6-1
STD-551	Plug	6-1	25C-22	Stud	2-1
STD-553	Screw	6-7	31C-12	Stud	1-1
STD-557	Dowel	1-1	31C-12	Stud	2-1
STD-596	Nut	1-11	31C-12	Stud	3-3
STD-587	Nut	3-7	31C-13	Stud	1-1
STD-619	Washer	1-3	31C-19	Stud	2-1
STD-678	Washer	1-11	31CD-17	Stud	2-1
STD-678	Washer	2-5	38-13	Stud	1-1
STD-684	Nipple	3-7	50-15	Stud	1-1
STD-690	Washer	5-3	383-B	Nut	3-7
STD-700	Elbow	3-3	1028-B	Ball	1-5
STD-713	Pin	5-3	1102	Plug	1-1
STD-783	Plug	2-1	1102	Plug	2-1
STD-784	Plug	2-1	1102	Plug	3-3
STD-853	Tee	6-7	1182-B3	Spark Plug	4-1
STD-872	Nut	1-11	1182-F3	Spark Plug	4-1
STD-872	Nut	5-3	1182-V4	Spark Plug	4-1
STD-1045	Gasket	1-5	8313	Gasket	2-7
STD-1045	Gasket	6-1	45530	Ring	1-9
STD-1065	Dowel	1-7	45688	Flange	1-7
STD-1111	Elbow	1-1	60009	Key	3-5
STD-1196	Hose	6-3	60025	Screw	3-7
STD-1198	Bolt	1-7	60096	Gasket	2-5
STD-1211	Plug	1-7	60311	Plug	3-1
STD-1214	Screw	1-7	60398	Bushing	3-7
STD-1227	Washer	6-1	60403	Pin	3-1
STD-1409	Nut	1-11	60430	Cover	2-7
STD-1409	Nut	6-1	60592	Gasket	6-5
STD-1410	Nut	3-3	60803	Strap	1-11
STD-1410	Nut	4-1	60820	Gasket	6-1
STD-1410	Nut	5-2	60821	Tube Assy.	3-7
STD-1411	Nut	1-11	60831	Rocker Assy.	3-7
STD-1411	Nut	2-7	60882	Gear	1-7
STD-1411	Nut	5-3	60890	Tube Assy.	3-7
STD-1411	Nut	6-1	60928	Tube Assy.	3-7
STD-1411	Nut	6-5	61084	Spring	1-5
STD-1420	Nut	2-3	61098	Adapter Assy.	2-7
STD-1433	Bolt	6-1	61151	Shaft	1-9
STD-1623	Insert	1-1	61163	Gear	4-1
STD-1727	Washer	4-1	61173	Gasket	2-6
STD-1727	Washer	5-3	61174	Shaft	2-3
STD-1774	Pin	2-7	61175	Adapter	2-1
STD-1856	Screw	2-6	61183	Gasket	2-7
STD-1882	Screw	2-5	61227	Lever	1-1
STD-1925	Screw	3-7	61247	Cover	3-7
STD-2090	Nut	3-7	61253	Spacer	1-7
STD-2180	Hose	3-7	61259	Flange	3-3
STD-2213	Screw	1-7	61358	Plug	6-1

Williamsport Plant

**NUMERICAL INDEX (Cont.)**

PART NO.	PART NAME	PAGE NO.	PART NO.	PART NAME	PAGE NO.
61376	Connection	6-1	69373	Bearing	3-1
61377	Connection	6-1	69401	Ring	3-1
61378	Screen	6-1	69436	Spring	2-6
61381	Tube Assy.	6-1	69679	Stud	1-1
61400	Stud	2-1	69841	Piston	3-1
61510	Plug	1-7	69953	Starter	5-2
61520	Bearing	1-5	69958	Piston	3-1
61531	Gasket	1-1	70396	Piston	3-1
61533	Bearing	1-5	71032	Bushing	1-3
61544	Plunger	1-9	71105	Tappet	1-5
61554	Cover	1-1	71160	Housing Assy.	2-1
61555	Plug	1-1	71481	Ring	3-7
61583	Cover Assy.	1-1	71596	Washer	2-7
61584	Valve	1-1	71831	Cylinder & Head Assy.	3-3
61631	Valve	3-5	71832	Cylinder & Head Assy.	3-3
61662	Bearing	3-1	71837	Cylinder & Head Assy.	3-3
61665	Gear	4-1	71838	Cylinder & Head Assy.	3-3
62123	Tube Assy.	1-3	71973	Gasket	6-3
62156	Rod Assy.	3-7	72057	Seat	3-3
62224	Gasket	4-1	72058	Seat	3-3
62289	Carburetor	6-5	72067	Bushing	1-7
62415	Plunger	2-6	72075	Seal	1-5
62417	Plug	2-6	72091	Ring	1-5
62531	Crankshaft Assy.	1-7	72434	Plug	3-1
62815	Housing	2-6	72496	Housing Assy.	2-1
62817	Screen Assy.	2-6	72566	Gear	1-7
62830	Carburetor	6-5	72877	Body	1-5
62916	Ring	3-1	72970	Gear Assy.	2-7
65006	Tube	3-5	73346	Flange	6-3
65007	Retainer	1-1	73411	Rod Assy.	3-7
65098	Cover	2-5	73412	Rod Assy.	3-7
66429	Valve	3-5	73413	Rod Assy.	3-7
66528	Seat	3-3	73414	Rod Assy.	3-7
66529-S	Guide	3-3	73817	Lockplate	1-9
66610	Bushing	3-3	73818	Gasket	2-1
66734	Stud	1-1	73938	Valve	3-5
66796	Insert	3-3	74068	Ring	1-3
67447	Bearing	1-5	74225	Nipple Assy.	6-7
68338	Ring	3-1	74323	Strut	5-3
68519	Rocker Assy.	3-7	74996	Gear Assy.	1-9
68593	Spacer	2-7	75072	Gear Assy.	1-9
68668	Spring	1-5	75312	Support Assy.	1-7
68751	Stud	1-1	75380	Link	5-3
68763	Bearing	1-5	75706	Camshaft	1-7
68786	Housing Assy.	2-1	75708	Shaft Assy.	1-9
68788	Housing Assy.	2-1	75906	Gasket	3-7
68790	Housing Assy.	2-1	76026	Belt	5-1
68792	Housing Assy.	2-1	76094	Camshaft	1-7
68974	Housing	2-6	76210	Starter	5-2
69340	Support Assy.	1-7	76529	Plug	1-5

Williamsport Plant

**NUMERICAL INDEX (Cont.)**

PART NO.	PART NAME	PAGE NO.	PART NO.	PART NAME	PAGE NO.
76534	Shim	5-3	78158	Bracket	5-3
76923-48S70-63	Lead Assy.	4-1	78290	Plunger Assy.	3-5
76923-48S90-63	Lead Assy.	4-1	78524	Socket	3-5
76943-S	Guide	3-3	78531	Body	2-3
77309	Bushing	1-9	05K19423-S	Oil Pump Impeller Kit	2-3
77467	Spring	1-5	36B19484	Pulley	5-1
78027	Bolt	3-1	68C19622	Gear	4-1
78030-S	Connecting Rod Assy.	3-1	13S19646	Gear	1-7